



SMOKE DETECTOR
M75117

**IONIZATION SMOKE DETECTOR
WITH INTERCONNECT**

GENERAL DESCRIPTION

The M75117 is a low-current CMOS circuit providing all of the required features for an ionization-type smoke detector. A networking capability allows as many as 125 units to be interconnected so that if any unit senses smoke, all units will sound an alarm. In addition, special features are incorporated to facilitate alignment and test of the finished smoke detector. can be used in numerous other battery-operated safety/security applications.

FEATURES

- Piezoelectric Horn driver.
- Guard outputs on both sides of detect Input.
- Low-battery trip point, internally set , can be altered via external resistor.
- Detect threshold, internally set , can be altered via external resistor.
- Pulse testing for low-battery uses LED for battery loading.
- Comparator Output for Detect.
- Internal Reverse Battery Protection.
- I/O Pin allows up to 125 units to be connected for common signaling.
- Power-on reset places IC in standby mode.

PIN ASSIGNMENT

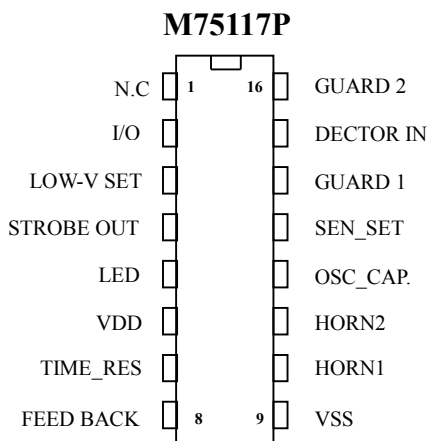



**IONIZATION SMOKE DETECTOR
WITH INTERCONNECT**

PIN AND CIRCUIT DESCRIPTION

Pin No	Pin Name	I/O	Function
1	N.C	—	No Connection
2	I/O	I/O	This pin to allow multiple smoke detectors to be command. If any single unit detect smoke (I/O is driven high), all connected units will sound their associated horns. The Led is suppressed when an alarm is signaled from an interconnected unit. An internal NMOS device acts as a charge dump to aid in applications involving a large (distributed) capacitance on pin 2. The charge dump is activated only on the removal of a local alarm.
3	LOW-V SET	I	The low battery threshold is set internally by a voltage divider connected between VDD and VSS. The threshold can be increased by connecting a resistor to VDD. The threshold can be decreased by connecting a resistor to VSS. It will be a slight interaction here due the common voltage divider network. The battery voltage level is checked every 40 seconds during the 10mA, battery loading remains at 10 mA. 10ms LED pulse.
4	STROBE OUT	O	Comparator Output for Detect
5	LED	O	The 9 Volt battery level is checked every 40 seconds during the LED pulse. The battery is loaded via a 10mA pulse for 11.6 ms.
6	VDD	—	Power supply
7	TIME_RES.	I	A resistor between this pin and VDD is part of the oscillator and sets the capacitor charge and discharge current (default 8.2M Ω) .
8	FEEDBACK	I	This pin input to the feedback electrode. If the FEEDBACK pin is not used, it must be connected to VDD or VSS.
9	VSS	—	Ground
10	HORN1	O	These two pins are used in conjunction with external passive components and a self-resonating piezoelectric transducer. HORN1 is connected to the piezo metal support electrode; the complementary output, HORN2, is connected to the ceramic electrode. A continuous modulated tone indicates either a local or remote alarm condition. A short (10ms) chirp indicates a low-battery chirp occurs almost simultaneous with the visible LED flash.
11	HORN2	O	
12	OSC_CAP.	I	A capacitor between this pin and VSS is part of the oscillator and sets charge and discharge time (default 0.1 μ F).
13	SEN_SET	I	The detector sensitivity to smoke is set internally by a voltage divider connected between VDD and VSS. The sensitivity can be externally adjusted to the individual characteristics of the ionization chamber by connecting a resistor between pin13 and VDD, or between pin 13 and VSS. It will be a slight interaction here due the common voltage divider network.
14	GUARD1	I	This will keep surface leakage currents to a minimum and provide a method of measuring the input voltage without loading the ionization chamber.
15	DECTOR IN	I	This pin is the ionization-type smoke detector input.
16	GUARD2	I	The voltage at these pins will be within 100mV of the input signal. This will keep surface leakage currents to a minimum and provide a method of measuring the input voltage without loading the ionization chamber.



**IONIZATION SMOKE DETECTOR
WITH INTERCONNECT**

M75117

ABSOLUTE MAXIMUM RATING

Parameter	Sym.	Rating	Unit
Supply Voltage Range	V _{DD}	-0.5 ~ 13	V
Input Voltage Range	V _{IN}	-0.3 to V _{DD} + 0.3	V
Input Current	I _{IN}	10	mA
Operating Temperature Range	T _A	-10 ~ 60	°C
Storage Temperature Range	T _S	-35 ~ 125	°C

DC ELECTRICAL CHARACTERISTICS

(Voltage referenced to V_{SS}, T_A=25°C)

Characteristics	Sym.	V _{DD}	Min.	Typ.	Max.	Unit	Conditions
Operating Voltage	V _{DD}	—	6.0	—	12	V	
Output Voltage	V _{OH}	7.2	6.3	—	—	V	Piezoelectric Horn Drivers (I _{OH} = -16 mA)
		9.0	8.5	8.8	—	V	Comparators (I _{OH} = -30 μA)
	V _{OL}	7.2	—	—	0.9	V	Piezoelectric Horn Drivers (I _{OL} = +16 mA)
		9.0	—	0.1	0.5	V	Comparators (I _{OL} = +30 μA)
	V _{OL}	7.2	—	—	3.0	V	Led Driver (I _{OL} = 10 mA)
Output Impedance, Active Guard	Lo-Z	9.0	—	—	10	KΩ	Pin 14
	Hi-Z	9.0	—	—	1000	KΩ	Pin 16
Operating Current	I _{DD}	9.0	—	5.0	9.0	μA	R _{BIAS} = 8.2 MΩ
		12.0	—	—	12.0	μA	
Input Current	I _{IN}	9.0	—	—	±1.0	pA	Detect (40% R.H.)
		9.0	—	—	±0.1	μA	Pin 8
		—	—	—	±6.0	pA	@50°C, Pin 15
Internal Set Voltage	V _{LOW}	9.0	7.2	—	7.8	V	Low Battery
	V _{SET}	—	47	50	53	%V _{DD}	Sensitivity
Hysteresis	V _{HYS}	9.0	75	100	150	mV	
Offset Voltage (measure at V _{IN} =V _{DD} /2)	V _{OS}	9.0	—	—	±100	mV	Active Guard
		9.0	—	—	±50	mV	Detect Comparator
Input Voltage Range	V _{IN}	—	V _{SS} -10	—	V _{DD} +10	V	Pin 8
Input Capacitance	C _{IN}	—	—	5.0	—	pF	
Common Mode Voltage Range	V _{CM}	—	0.6	—	V _{DD} -2	V	Pin 15
I/O Current	I _{IH}	—	25	—	100	μA	Input, V _{IH} = V _{DD} -2 (Pin 2)
	I _{OH}	—	-10	—	-25	mA	Output, I _{OH} = V _{DD} -2 (Pin 2)

TIMING PARAMETERS

(C=0.1 μF, R_{BIAS} = 8.2MΩ, V_{DD} = 9.0V, T_A=25°C)

Characteristics		Sym.	Min.	Max	Unit
Oscillator Period	No Smoke	t _{CI}	1.46	1.85	s
	Smoke		37.5	45.8	ms
Oscillator Rise Time		t _r	10.1	12.3	ms
Horn Output (During Smoke)	On Time	PW _{on}	120	208	ms
	Off Time	PW _{off}	60	164	ms
LED Output Pulses	Between	t _{LED}	35.0	44.5	s
	On Time	PW _{on}	10.1	12.3	ms
Horn Output Pulses (During Low Battery)	On Time	t _{on}	10.1	12.3	ms
	Off Time	t _{off}	35.0	44.5	s



**IONIZATION SMOKE DETECTOR
WITH INTERCONNECT**

TIMING DIAGRAM

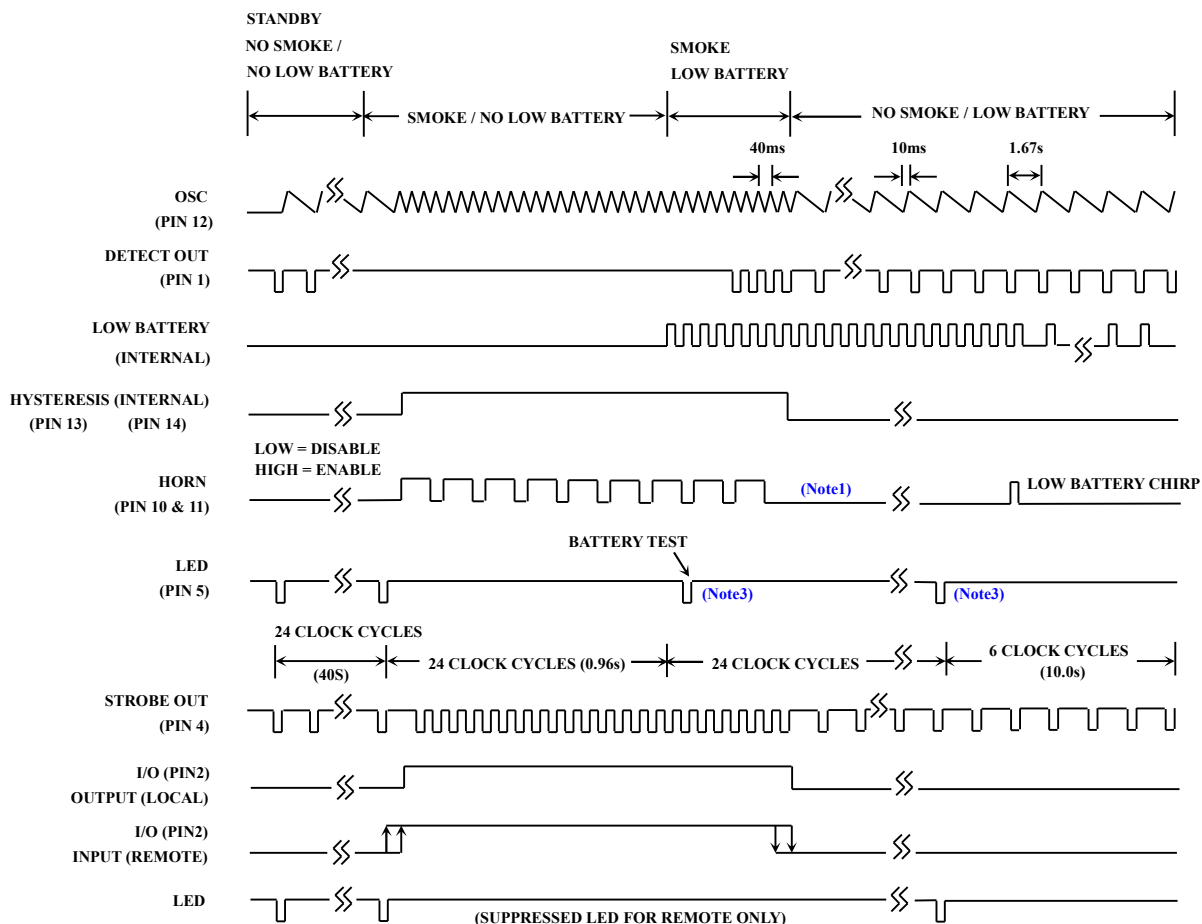

- Notes :
1. Horn modulation is self-completing. When going from smoke to no smoke , the alarm condition will terminate only When horn is off.
 2. Comparators are strobed on once per clock cycle (1.67s for no smoke , 40 ms for smoke).
 3. Low battery comparator information is latched only during LED pulse.



**IONIZATION SMOKE DETECTOR
WITH INTERCONNECT**

BLOCK DIAGRAM

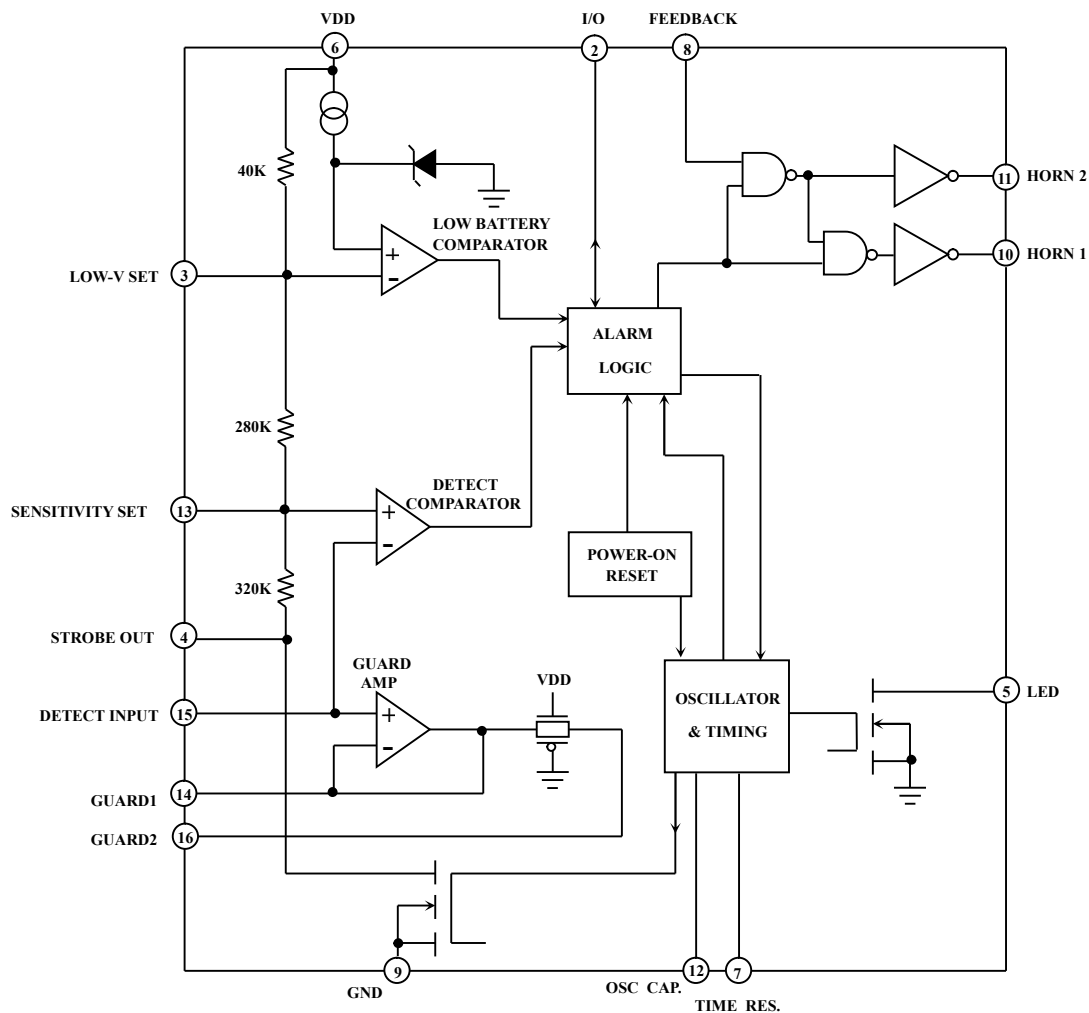



IONIZATION SMOKE DETECTOR
WITH INTERCONNECT

APPLICATION DIAGRAM

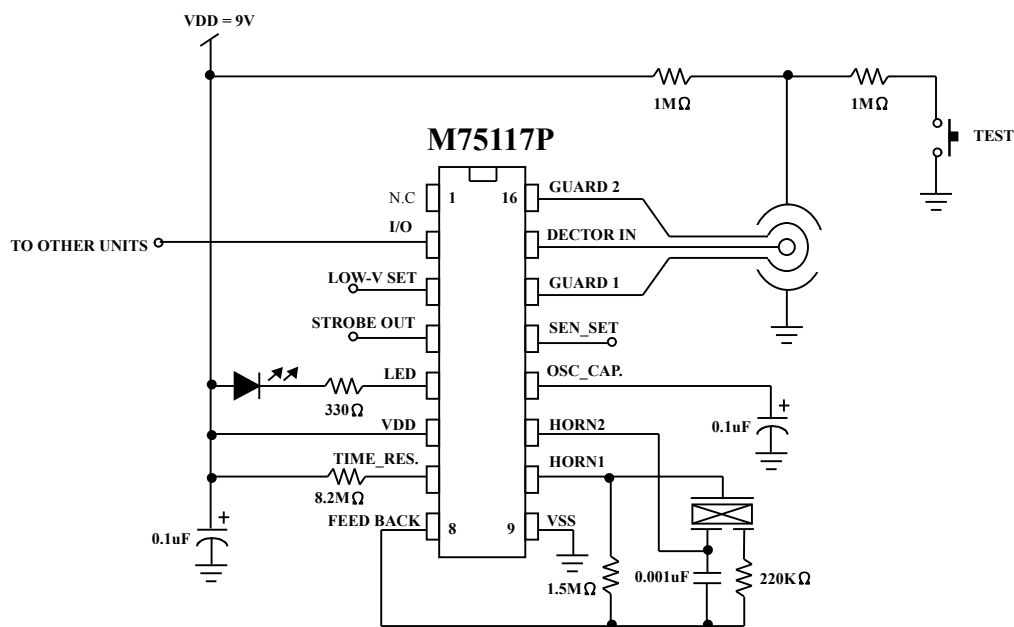

* All specs and applications shown above subject to change without prior notice.
(以上電路及規格僅供參考,本公司得逕行修正)