



EN/DECODER
M5D/F

GENERAL DESCRIPTION 功能敘述

The M5D/F is a CMOS ASIC decoder. It will de-code the serial data from data input. The VT signal will go high and data will be copied to the output if address are checked the same.

FEATURES 產品特長

- Same Rosc matched to the ENCODER M5E
- $3^{12} = 531,411$ codes, "0"、"X"、"1" Tri-states.
- 3 cycles checked each time
- Address / Data types :
 - M5D : 4 data type. (Latched)
 - M5D-M : Momentary data outputs
 - M5F : Full address type

APPLICATIONS 產品應用

- Car/home alarm system, garage control etc..

BLOCK DIAGRAM 功能方塊圖

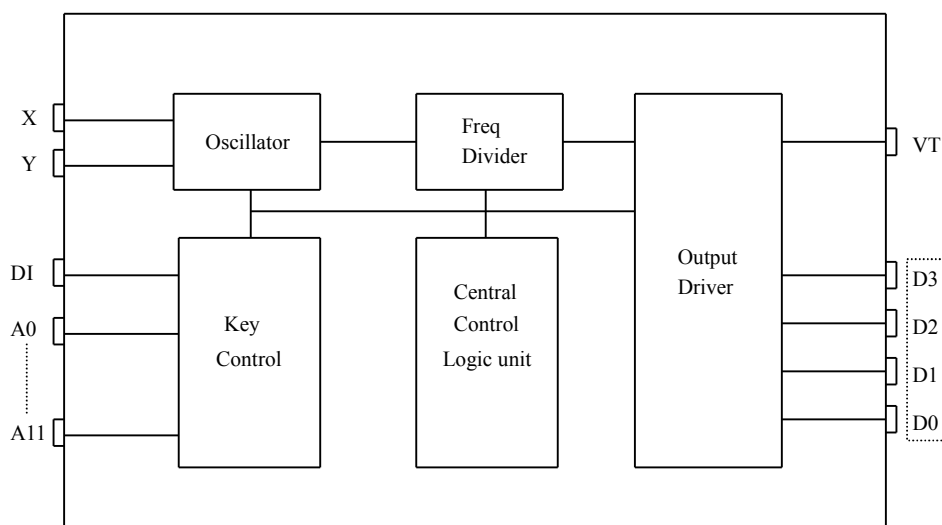

*All specs and applications shown above subject to change without prior notice.
(以上電路及規格僅供參考,本公司得逕行修正)



EN/DECODER
M5D/F

ABSOLUTE MAXIMUM RATING

(TA=25°C)

Parameter	Rating	Unit
Supply Voltage	-0.3 to 15	V
Input Voltage	-0.2~V _{DD} +0.2	V
Operating Temperature	-20 to 70	°C
Storage Temperature	-50 to 125	°C

ELECTRICAL CHARACTERISTICS

Characteristics	Sym.	Min.	Typ.	Max.	Unit	Conditions
Operating Voltage	V _{DD}	2.4	—	15	V	
Quiescent Current	I _{SB}	—	0.1	1	μA	
Operating Current	I _{OP}	—	0.1	0.5	mA	No load
Output Drive Current	I _O	—	2	—	mA	@V _{DS} =1.2V
Input Voltage	V _{IH}	V _{DD} -0.2	V _{DD}	V _{DD}	V	
	V _{IL}	V _{SS}	V _{SS}	V _{SS} +0.2		
Oscillator Frequency	F _{osc}	—	76	—	KHz	External±30%, R _{osc} =220KΩ

PIN DESCRIPTION

No.	M5D	M5F	Description
1~8	A0~A7	A0~A7	3 states address inputs
9	VSS	VSS	Negative power supply
10~13	D0~D3	A8~A11	Data outputs/Address inputs
14	DI	DI	Data input
15	Y	Y	Oscillator output
16	X	X	Oscillator input
17	VT	VT	Valid transmit
18	VDD	VDD	Positive power supply

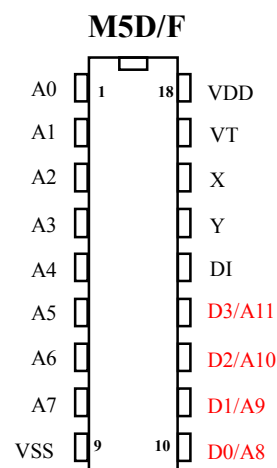

CAD :	設計 :	審核 :	企劃應用 :
-------	------	------	--------



EN/DECODER
M5D/F

TIMING WAVEFORM

(1) BIT FORMAT

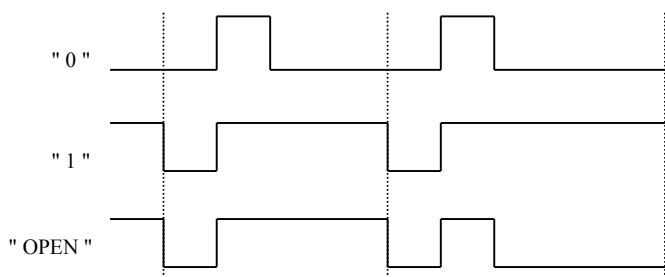

(2) TIMING DIAGRAM

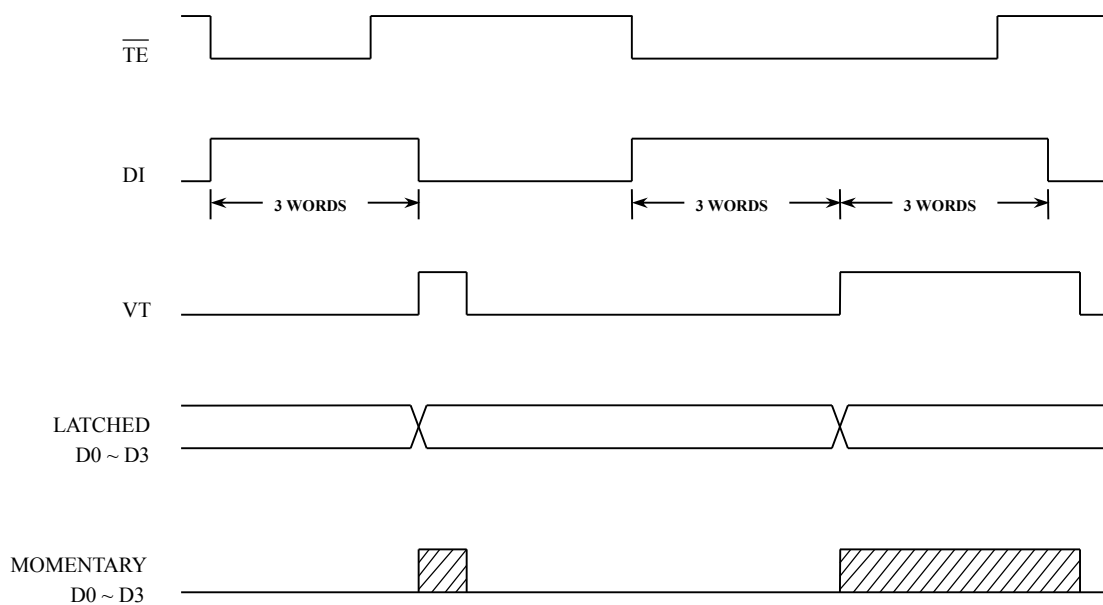



OPERATING FLOWCHART

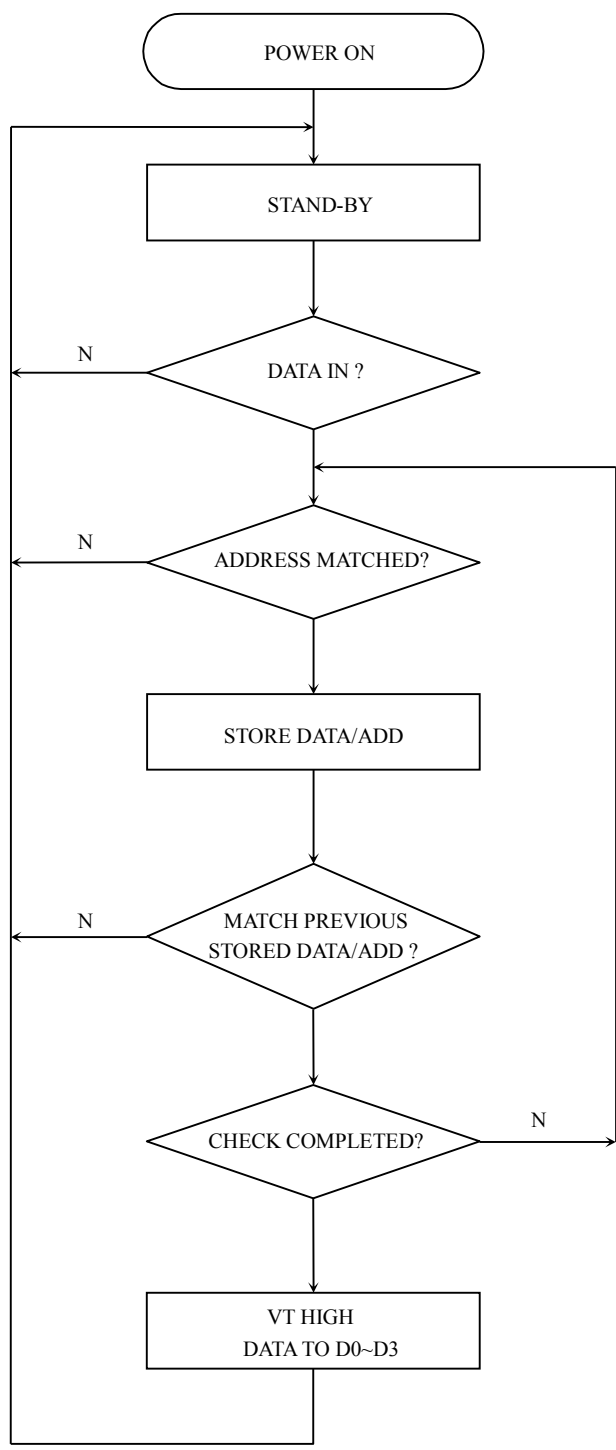



RECONNENDED OSCILLATOR PARAMETERS

Rosc (KΩ)	M5D/F (KHz)
75	218
82	199
91	185
100	170
120	142
150	115
180	95
200	86
220	78
270	63
300	57
330	51
360	49

DATA OUTPUT

M5E (D0~D3)	M5D/F (D0~D3)
0 (VSS)	0 (VSS)
X (OPEN)	0 (VSS)
1 (VDD)	1 (VDD)
POWER ON	0 (VSS)

Freq-Rosc Chart
(@VDD=12V)

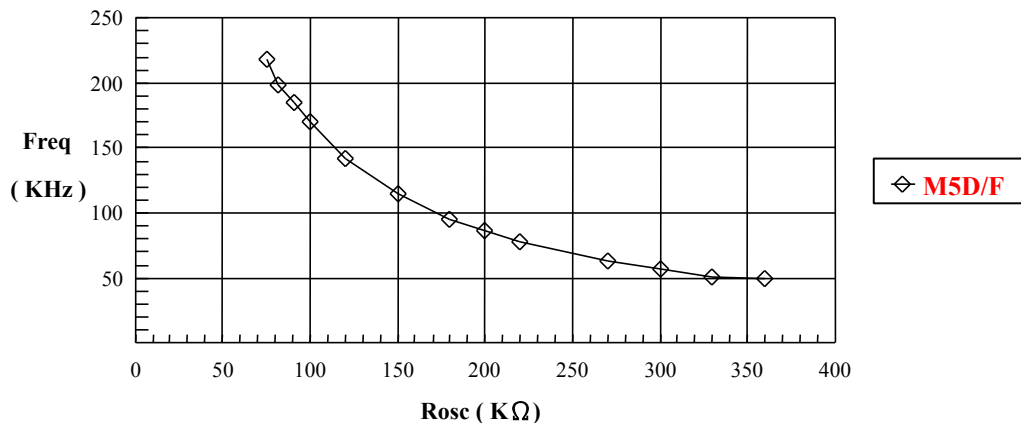



EN/DECODER
M5D/F

APPLICATION DIAGRAM 參考電路圖

(1) DATA TYPE

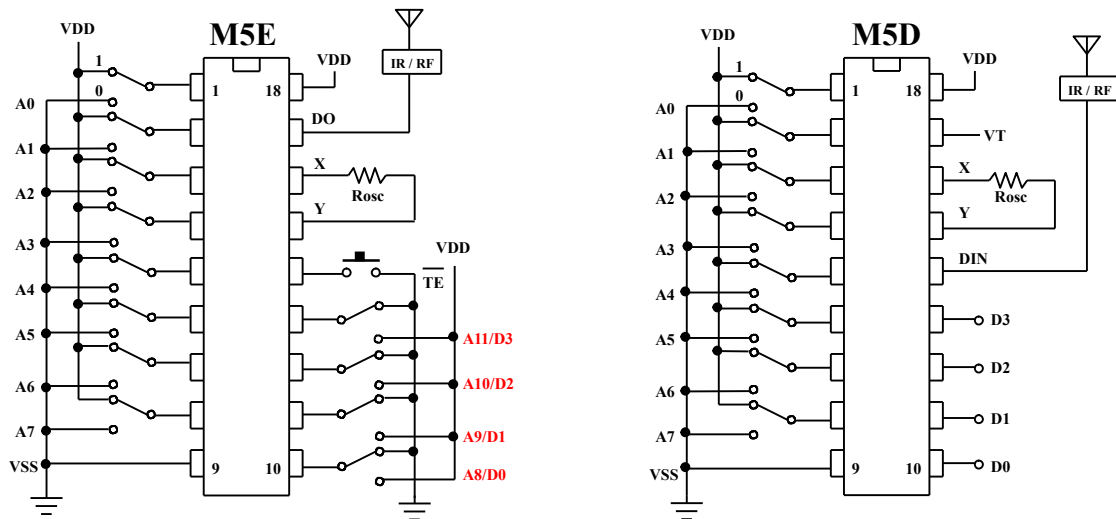

(2) FULL ADDRESS TYPE

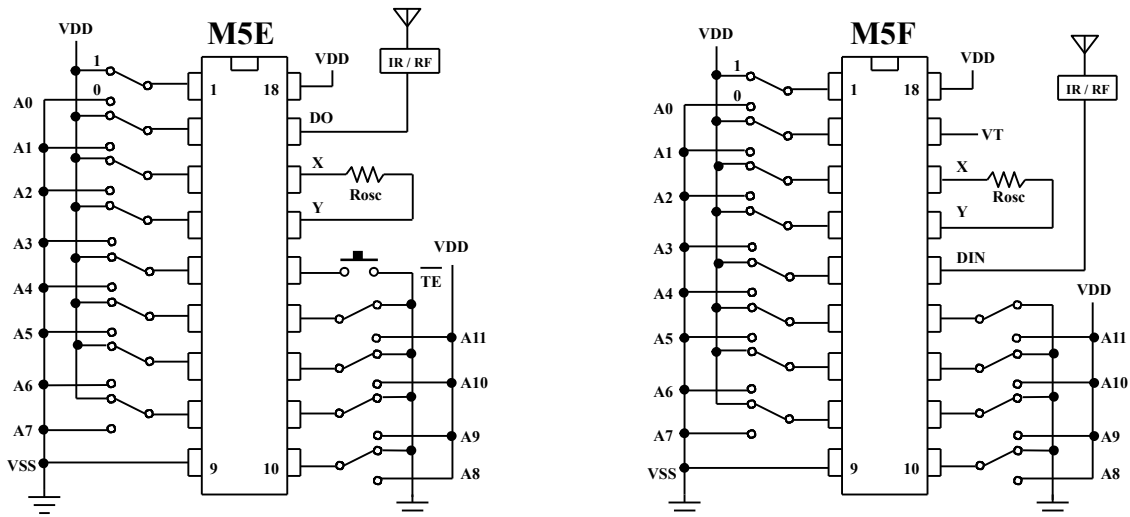



APPLICATION DIAGRAM 參考電路圖 (SOP PACKAGE)

(3) DATA TYPE

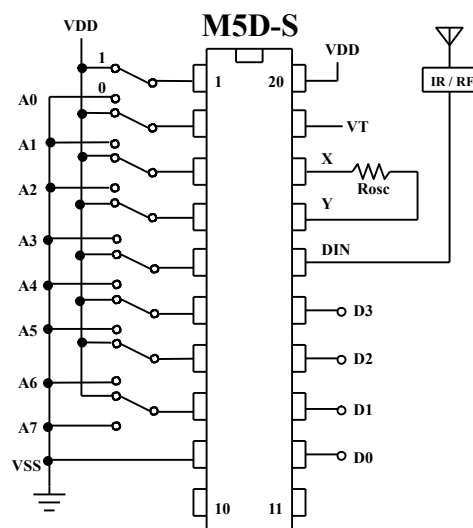
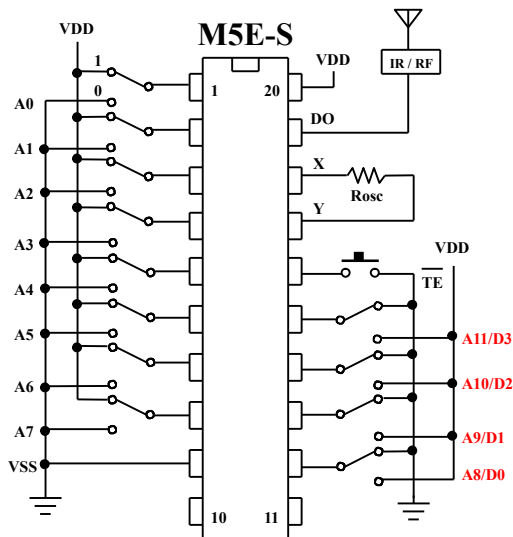
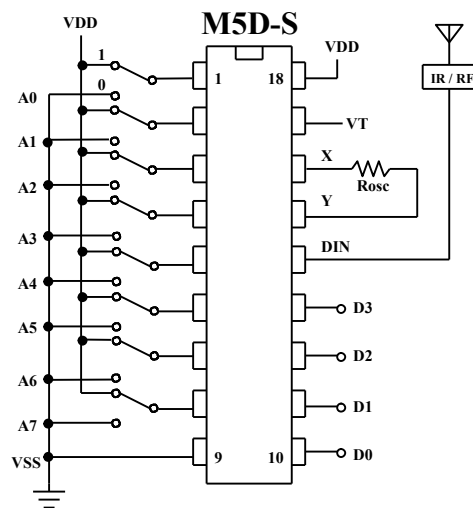
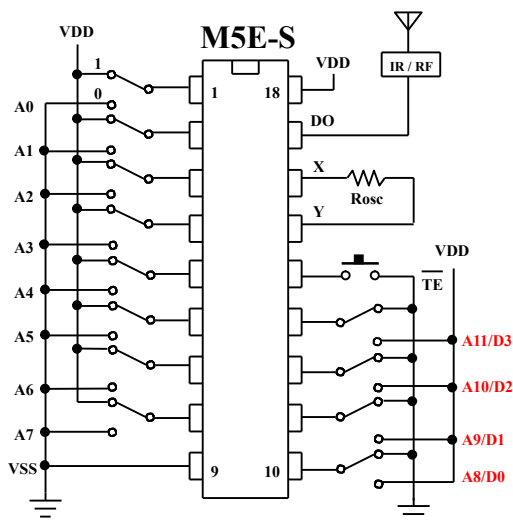



APPLICATION DIAGRAM 參考電路圖 (SOP PACKAGE)

(4) FULL ADDRESS TYPE

