



GENERAL DESCRIPTION 功能敘述

The M3D/F is a CMOS ASIC decoder. It will de-code the serial data from data input. The VT signal will go high and data will be copied to the output if address are checked the same. The address input are trinary i.e. LOW(0) 、 OPEN(X) and HIGH(1).

FEATURES 產品特長

- Same Rose matched to the Encoder M3E,.
- $3^{12} = 531,411$ codes, “0” 、 ”X” 、 ”1” Tri-states.
- 3 cycles checked each time
- S.O.Package : suffix-S.
- Address / Data types :
 - M3D-L : Latch data outputs.
 - M3D-M : Momentary data outputs.
 - M3F : Full address type.

APPLICATIONS 產品應用

- Car/home alarm system, garage control etc..

BLOCK DIAGRAM 功能方塊圖

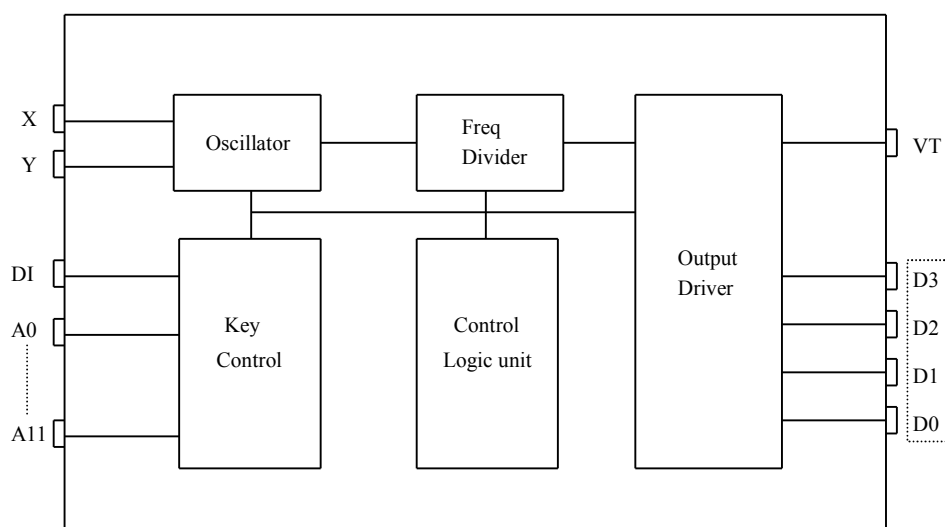

*All specs and applications shown above subject to change without prior notice.

(以上電路及規格僅供參考,本公司得逕行修正)



ABSOLUTE MAXIMUM RATING

(TA=25°C)

Parameter	Rating	Unit
Supply Voltage	-0.3 to 12	V
Input Voltage	-0.2~V _{DD} +0.2	V
Operating Temperature	-20 to 70	°C
Storage Temperature	-50 to 125	°C

ELECTRICAL CHARACTERISTICS

Characteristics	Sym.	Min.	Typ.	Max.	Unit	Conditions
Operating Voltage	V _{DD}	2.4	—	12	V	
Operating Current	I _{OP}	—	0.1	1	mA	No load
Quiescent Current	I _{SB}	—	0.1	0.5	μA	
Output Drive Current	I _O	—	2	—	mA	@V _{DS} =1.2V
Input Voltage	V _{IH}	V _{DD} -0.2	V _{DD}	V _{DD}	V	
	V _{IL}	V _{SS}	V _{SS}	V _{SS} +0.2		
Oscillator Frequency	F _{osc}	—	76	—	KHz	External±30%, R _{osc} =220KΩ

PIN DESCRIPTION

No.	M3D	M3F	Description
1~8	A0~A7	A0~A7	3 States address inputs
9	VSS	VSS	Negative power supply
10~13	D0~D3	A8~A11	Data outputs/Address inputs
14	DI	DI	Data input
15	Y	Y	Oscillator output
16	X	X	Oscillator input
17	VT	VT	Valid transmit
18	VDD	VDD	Positive power supply



EN/DECODER
M3D /F

TIMING WAVEFORM

(1) Bit format

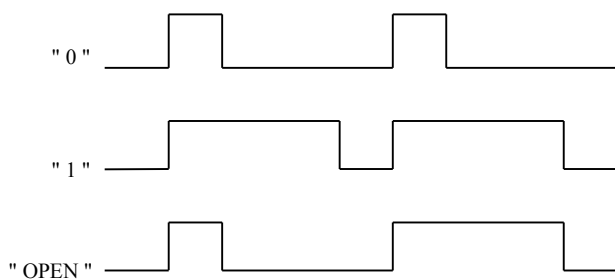

(2) TIMING DIAGRAM

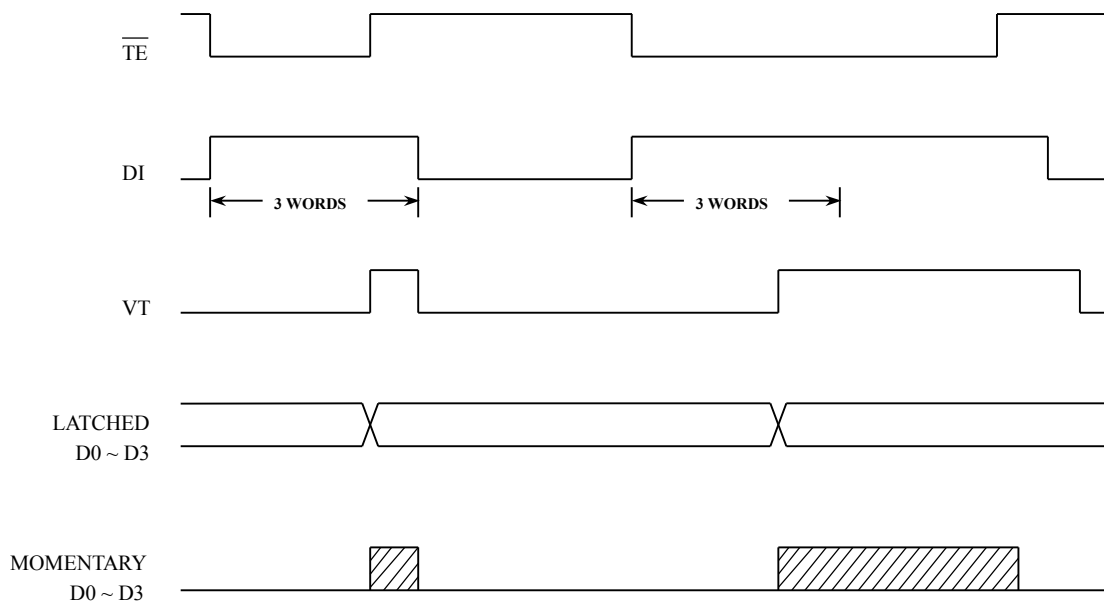



OPERATING FLOWCHART

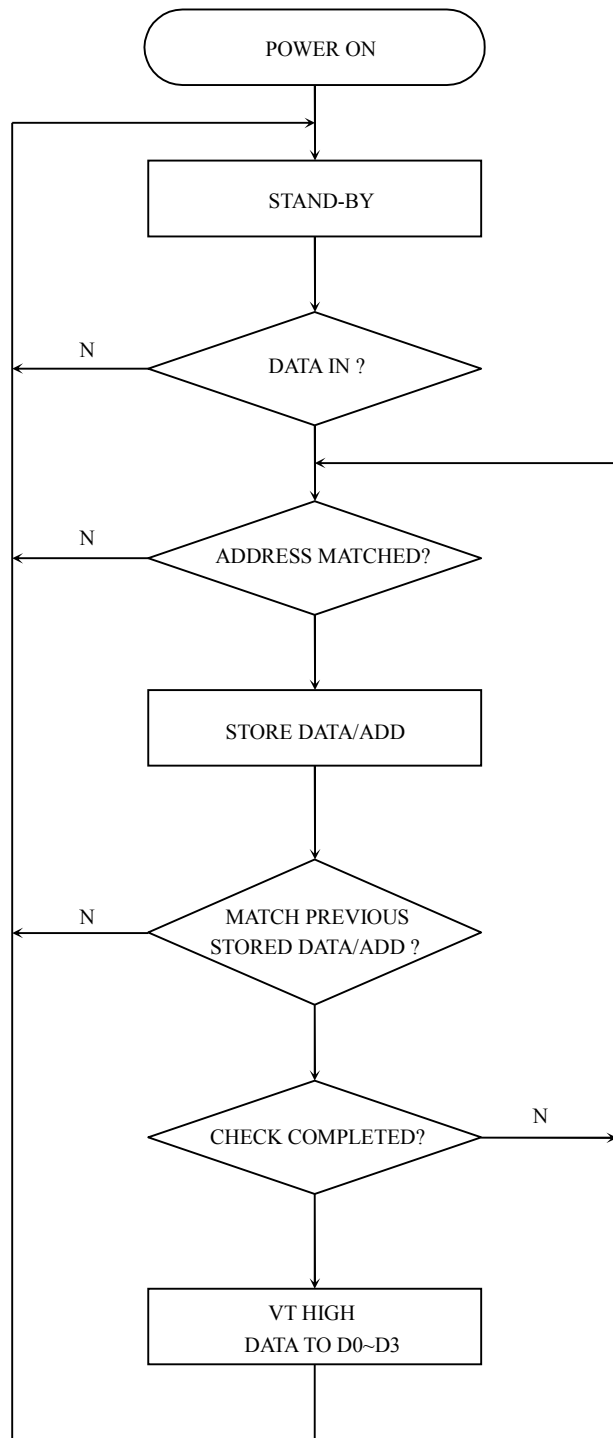



RECONNENDED OSCILLATOR PARAMETERS

Rosc (KΩ)	M3D/F (KHz)
75	218
82	199
91	185
100	170
120	142
150	115
180	95
200	86
220	78
270	63
300	57
330	51
360	49

DATA OUTPUT

M3E (D0~D3)	M3D /F (D0~D3)
0 (VSS)	0 (VSS)
X (OPEN)	1 (VDD)
1 (VDD)	1 (VDD)
POWER ON	0 (VSS)

Freq-Rosc Chart
(@Vdd=12V)

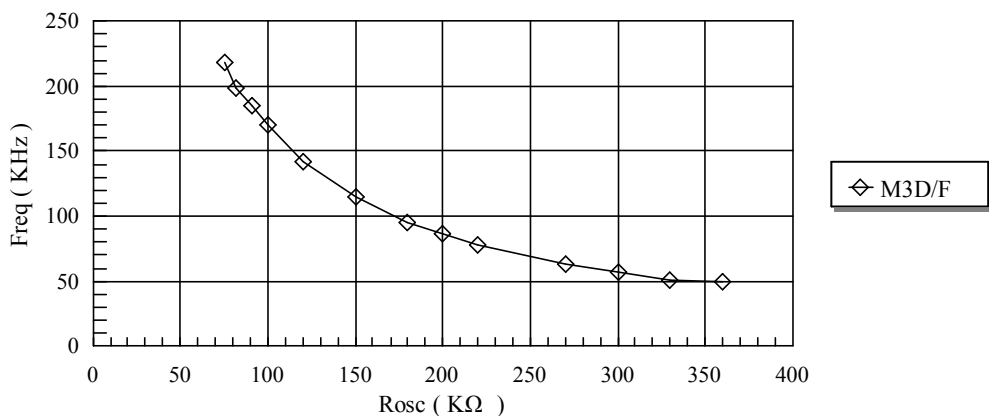

ADDRESS PIN INFORMATION

P/N	A0	A1	A2	A3	A4	A5	A6	A7	A8	A9	A10	A11
M3D	A0	A1	A2	A3	A4	A5	A6	A7	A8	A9	A10	A11
M3D-L1	A0	A1	A2	A3	A4	A5	A6	A7	D0	A8	A9	A10
M3D-L2	A0	A1	A2	A3	A4	A5	D0	D1	A6	A7	A8	A9
M3D-L3	A0	A1	A2	A3	A4	A5	A6	A7	A8	D0	D1	D2
M3D-L4	A0	A1	A2	A3	A4	A5	A6	A7	D0	D1	D2	D3
M3D-L5	A0	A1	A2	A3	A4	A5	D0	D1	A6	D2	D3	D4
M3D-L6	A0	A1	A2	A3	A4	A5	D0	D1	D2	D3	D4	D5
M3D-M1	A0	A1	A2	A3	A4	A5	A6	A7	D0	A8	A9	A10
M3D-M2	A0	A1	A2	A3	A4	A5	D0	D1	A6	A7	A8	A9
M3D-M3	A0	A1	A2	A3	A4	A5	A6	A7	A8	D0	D1	D2
M3D-M4	A0	A1	A2	A3	A4	A5	A6	A7	D0	D1	D2	D3
M3D-M5	A0	A1	A2	A3	A4	A5	D0	D1	A6	D2	D3	D4
M3D-M6	A0	A1	A2	A3	A4	A5	D0	D1	D2	D3	D4	D5



APPLICATION DIAGRAM 參考電路圖

(1) DATA TYPE

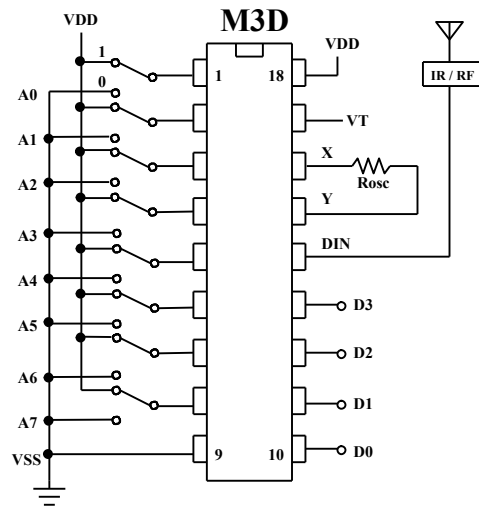
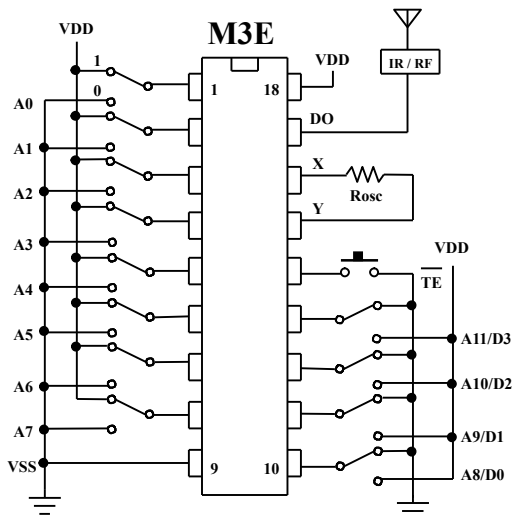

(2) FULL ADDRESS TYPE

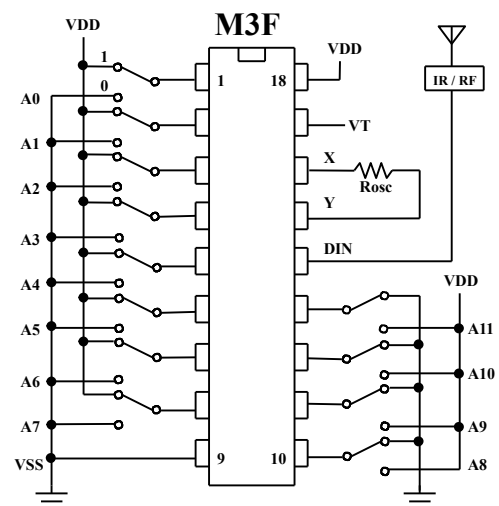
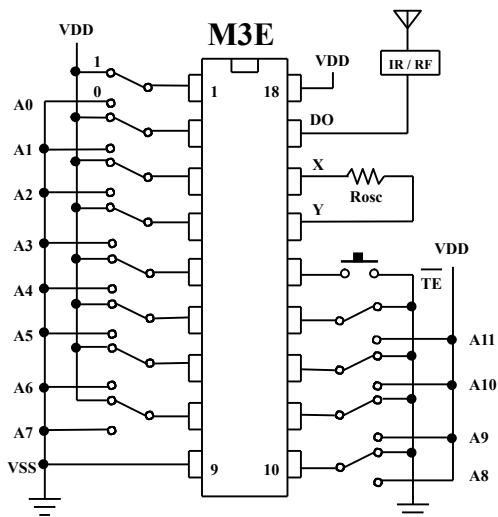



EN/DECODER
M3D /F

APPLICATION DIAGRAM 參考電路圖 (SOP PACKAGE)

(3) DATA TYPE

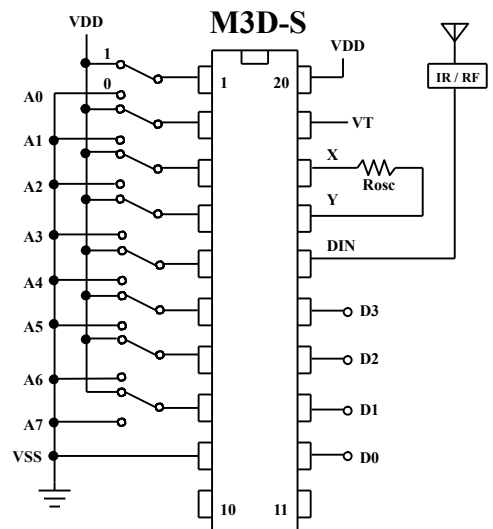
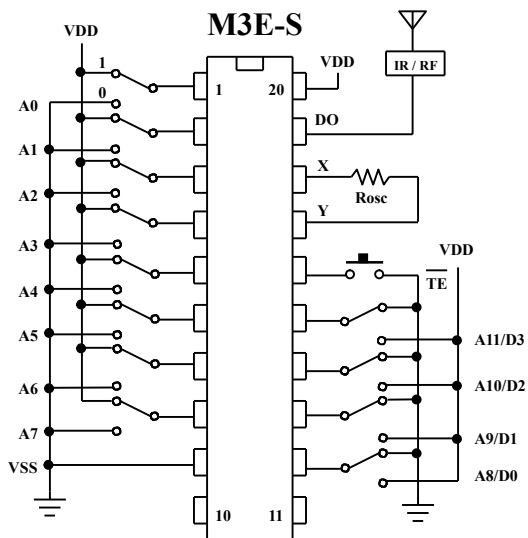
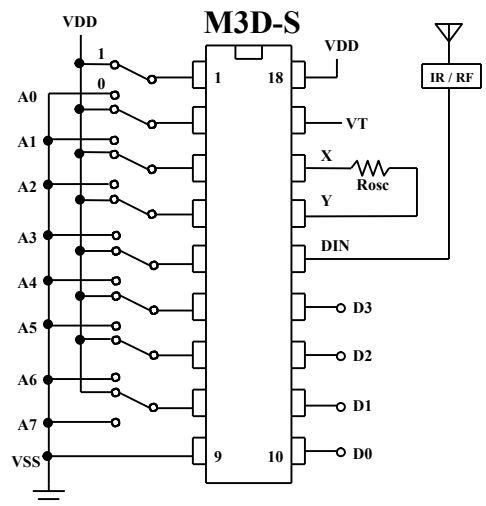
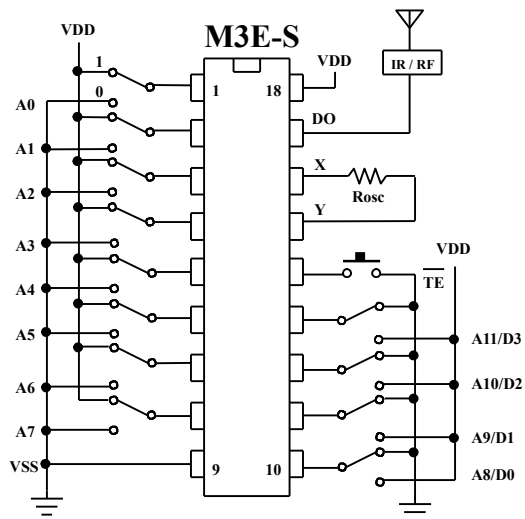



APPLICATION DIAGRAM 參考電路圖 (SOP PACKAGE)

(4) FULL ADDRESS TYPE

