



GENERAL DESCRIPTION 功能敘述

The M3162, is a CMOS ASIC encoder paired with M3172. It will en-code 12 parallel input and serially transmit them to the output when $\overline{\text{TE}}$ depressed. These address inputs are 3 states i.e. LOW(0) 、 OPEN(X) 、 HIGH(1).

FEATURES 產品特長

- CMOS technology
- $3^{12} = 531,411$ codes, "0" 、 "X" 、 "1" Tri-states.
- 4 cycles transmission each time.
- Built-in IR carrier : suffix-IR.

APPLICATIONS 產品應用

- Car/home alarm system, garage control etc..

BLOCK DIAGRAM 功能方塊圖

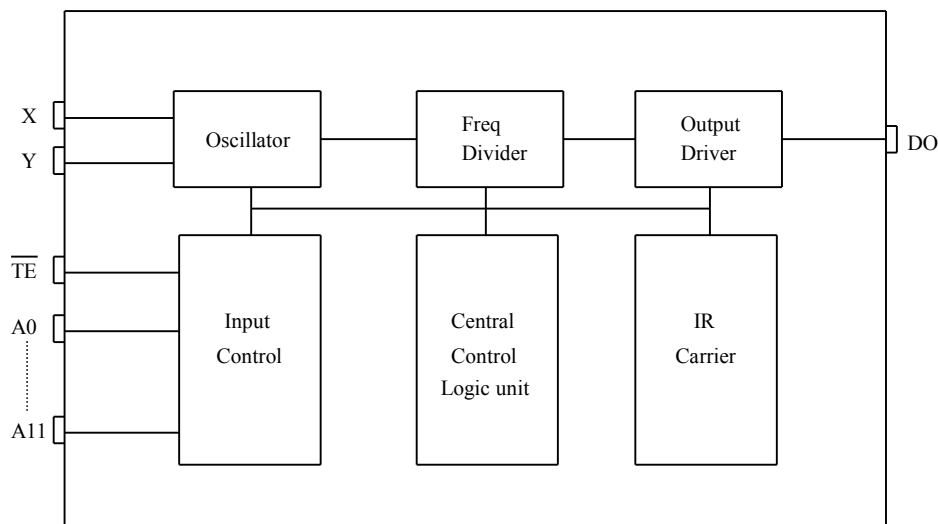

*All specs and applications shown above subject to change without prior notice.
(以上電路及規格僅供參考,本公司得逕行修正)



ABSOLUTE MAXIMUM RATING

(TA=25°C)

Parameter	Rating	Unit
Supply Voltage	-0.3 to 15	V
Input Voltage	-0.2~V _{DD} +0.2	V
Operating Temperature	0 to 70	°C
Storage Temperature	-50 to 125	°C

ELECTRICAL CHARACTERISTICS

Characteristics	Sym.	Min.	Typ.	Max.	Unit	Conditions
Operating Voltage	V _{DD}	2.4	—	15	V	
Operating Current	I _{OP}	—	0.1	1	mA	No load
Quiescent Current	I _{SB}	—	0.1	0.5	μA	
Output Drive Current	I _O	—	2	—	mA	@V _{DS} =1.2V
Input Voltage	V _{IH}	V _{DD} -0.2	V _{DD}	V _{DD}	V	
	V _{IL}	V _{SS}	V _{SS}	V _{SS} +0.2		
Oscillator Frequency	F _{osc}	—	76	—	KHz	External±30%, R _{osc} =390KΩ

PIN DESCRIPTION

No.	Pin name	Description
1~8	A0~A7	3 states address inputs
9	VSS	Negative power supply
10~13	A8/D0~A11/D3	3 states address inputs/ Data pin
14	$\overline{\text{TE}}$	Transmit enable
15	OSC2	Oscillator output
16	OSC1	Oscillator input
17	DO	Data output
18	VDD	Positive power supply

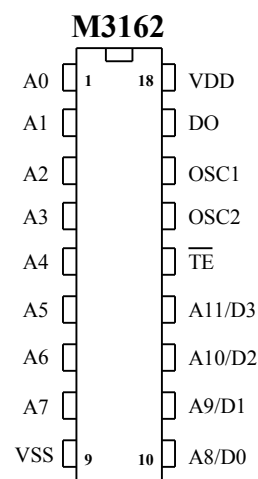



TIMING WAVEFORM

(1) Bit format

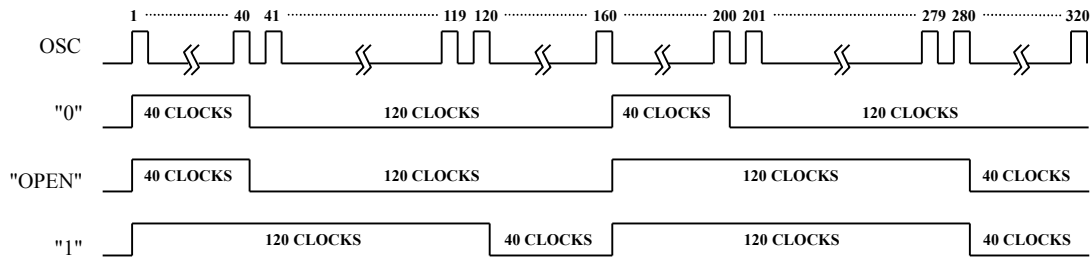

(2) TIMING DIAGRAM

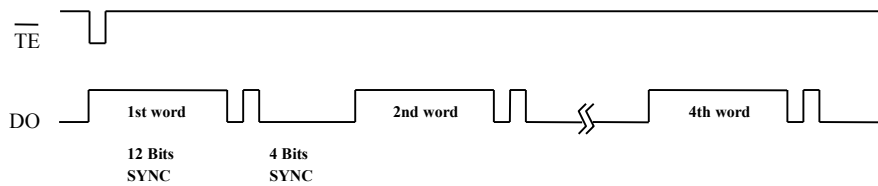



EN/DECODER
M3162

OPERATING FLOWCHART

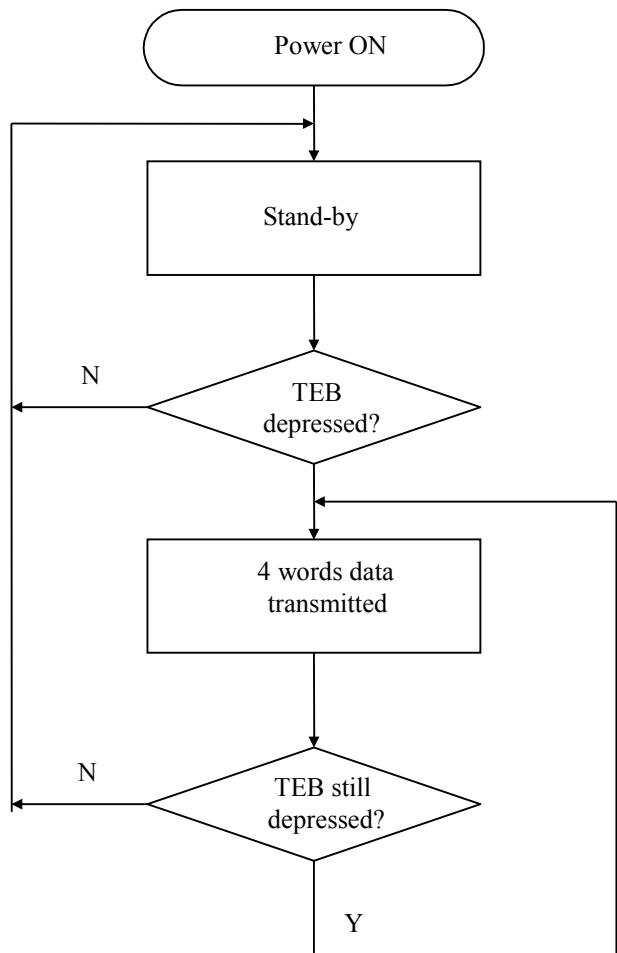



RECONNENDED OSCILLATOR PARAMETERS

Rosc(KΩ)	Freq(KHz)
75	384
100	298
150	200
180	170
220	138
270	113
300	103
360	86
390	78
430	73

DATA OUTPUT

M3162 (D0-D3)	M3172 (D0-D3)
0 (VSS)	0 (VSS)
X (OPEN)	1 (VDD)
1 (VDD)	1 (VDD)
POWER ON	0 (VSS)

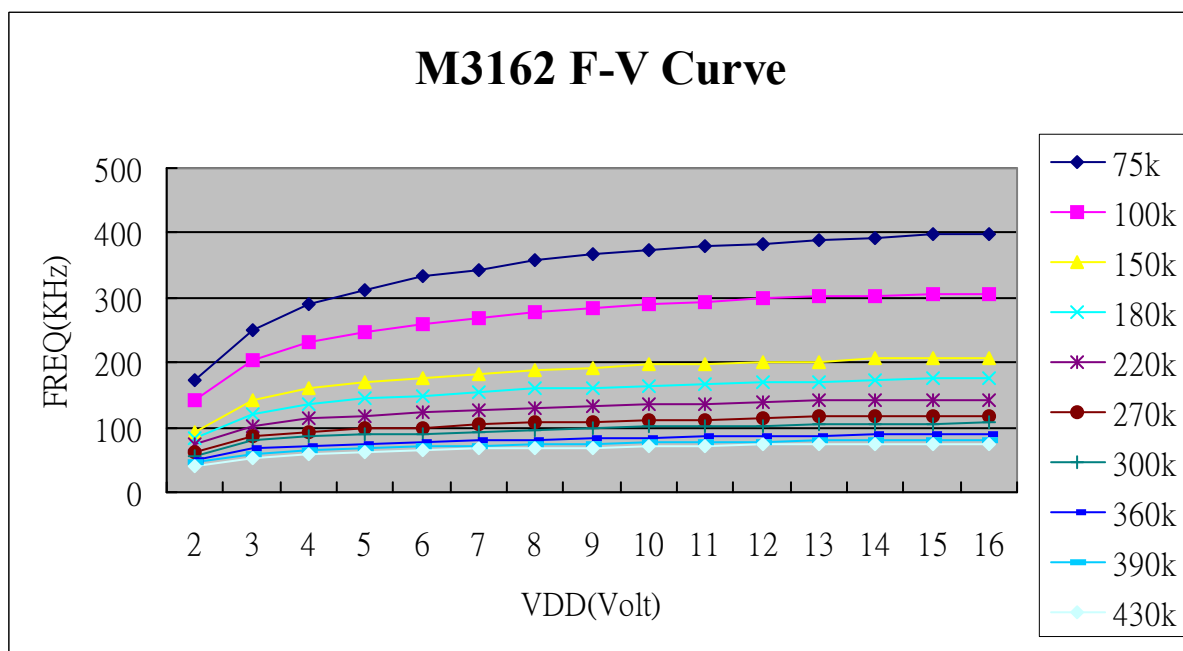



APPLICATION DIAGRAM 參考電路圖

IR 內建發射

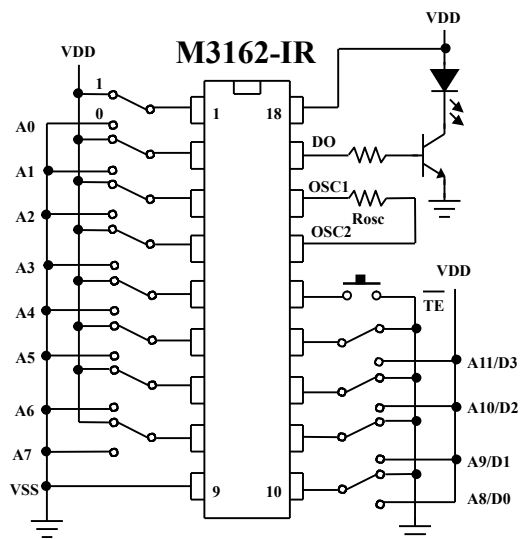
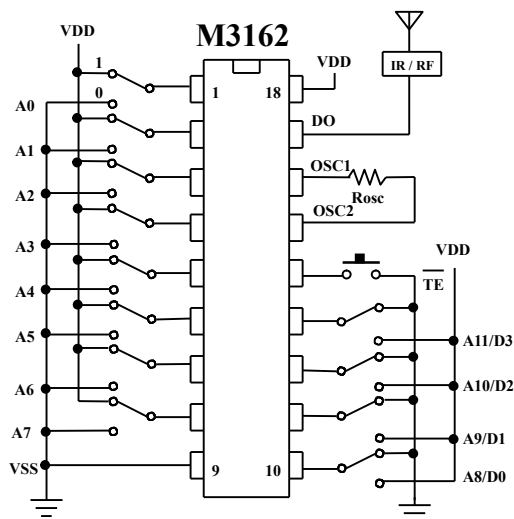

*All specs and applications shown above subject to change without prior notice.
(以上電路及規格僅供參考,本公司得逕行修正)