

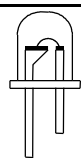

4 PATTERN DISPLAY

8 LED FLASH

閃爍圖形 IC

LED FLASH	
M1163	

FEATURES 功能敘述

- Operating voltage 2.4 ~ 5.5Volt.
- Use external R,C oscillator.
- LED output source current driver.
- \overline{TG} : Detector the DC motor speed via reed switch or Hall effect IC active low , motor counterclockwise.
- Display 4 pattern sequentially , customer's display pattern can be programmed by change one MASK layer.

P/N	LIST
M1163-1	Love Day
M1163-2	Holiday
M1163-3	Every Day

APPLICATION 產品應用

- Blinking LED , Function indicator , Xmas decoration , Toys.

ELECTRICAL CHARACTERISTICS 電氣規格

(@V_{DD}=4.5V unless otherwise specified)

Characteristics	Sym.	Min.	Typ.	Max.	Unit	REMARKS
工作電壓 Operating Voltage	V _{DD}	2.4	4.5	5.5	V	
工作電流 Operating Current	I _{OP}	—	0.1	0.5	mA	No load
推動電流 Driving Current	I _{oh}	—	-10	—	mA	@ V _{DS} =1.2V
振盪頻率 Oscillator Frequency	F _{OSC}	—	4.0	—	MHz	External OSC ±10% TOL. R _{osc} =4.7KΩ, C=20pF
工作溫度 Operating Temperature	Temp.	0	25	60	°C	

APPLICATION DIAGRAM 參考電路圖

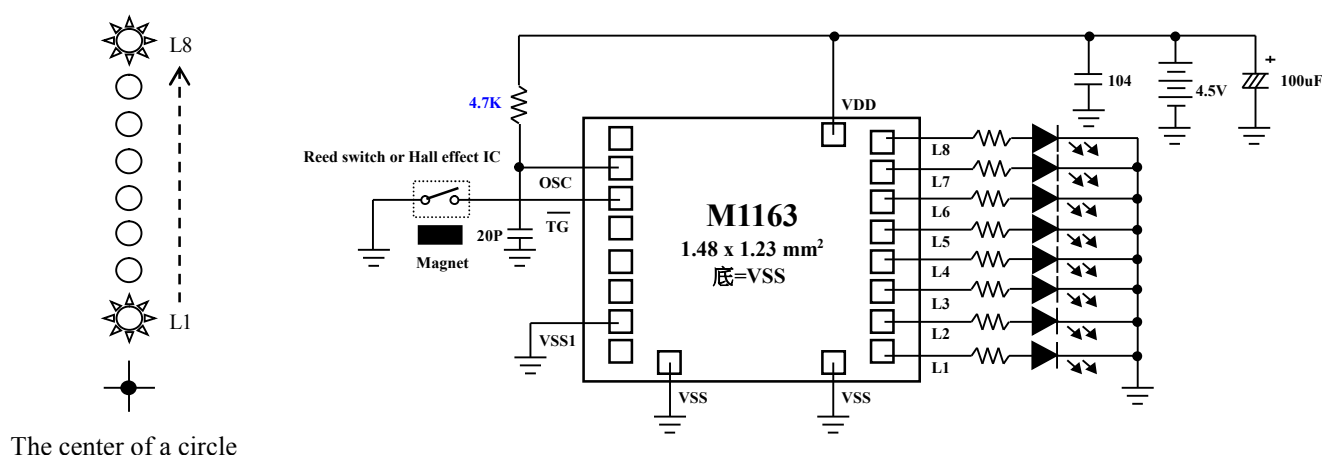

The center of a circle



4 PATTERN DISPLAY

8 LED FLASH

閃爍圖形 IC

LED FLASH	
M1163	

DISPLAY PATTERN

M1163-1 : Love Day

♥♥ SEXY LADY ♥♥
 ♫ COME ON ♫
 ♥ MISSING YOU ♥
 ♫ I LOVE YOU ♫

M1163-2 : Holiday

☀ MERRY X'MAS ☀
 🎉 HAPPY TIME 🎉
 HAPPY NEW YEAR
 🐕 GO! GO! GO! 🐕

M1163-3 : Every Day

👋 HELLO! 🎉 🎉 🎉
 🎉 HOW ARE YOU 🎉
 🖐 GIVE ME FIVE 🖐
 🙏 THANK YOU 🙏

PAD ASSIGNMENT & POSITION

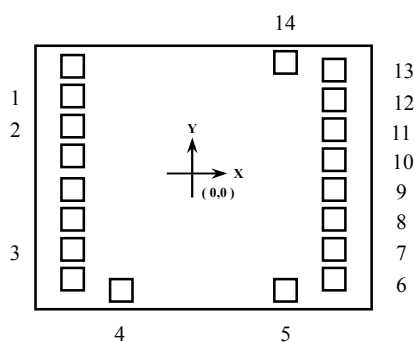

UNIT : um

No.	NAME	X	Y	No.	NAME	X	Y
1	OSC1	530.4	-332.7	8	L3	-530.4	165.7
2	TG	530.4	-212.7	9	L4	-530.4	33.3
3	VSS1	530.4	292.2	10	L5	-530.4	-86.7
4	VSS	324.8	487.7	11	L6	-530.4	-219.1
5	VSS	-329.7	487.7	12	L7	-530.4	-339.1
6	L1	-530.4	418.1	13	L8	-530.4	-471.5
7	L2	-530.4	285.7	14	VDD	-329.7	-490.5

* CHIP SIZE ~ 1.48 X 1.23 mm²

* IC substrate should be connected to VSS in PCB (PCB 上 IC 必須接 VSS)

*All specs and applications shown above subject to change without prior notice.
 (以上電路及規格僅供參考,本公司得逕行修正)