



DESCRIPTION

The M1971 is a high precision non-isolated buck driver with active PFC, specially designed for universal input offline constant current LED lighting. The driver with on-chip PFC circuit achieves high power factor and low THD. Operating in critical conduction mode, the power MOSFET switching loss is reduced and the inductor is fully utilized. The inductor current is sensed during the whole switching cycle. So it achieves high precision output current control, and excellent line regulation and load regulation.

The M1971 offers rich protection functions to improve the system reliability, including LED open circuit protection, LED short circuit protection, VCC under voltage protection, CS resistor open circuit protection and cycle by cycle current limit. All the protection functions are auto-recovery. The system reliability is further improved by the thermal regulation function. The output current is reduced when the driver is over temperature.

FEATURE

- Active PFC for High Power Factor and Low THD
- MOSFET Internal 600V, 0.8A Power MOSFET
- System Efficiency up to 95%
- $\pm 3\%$ LED Output Current Accuracy
- Excellent Line and Load Regulation
- Critical Conduction Mode Operation
- Ultra Low (30uA) Start Up Current
- LED Short/Open Protection
- Current Sensing Resistor Open Protection
- Cycle by Cycle Current Limit
- VCC Under Voltage Protection
- Auto Fault Recovery
- Thermal Regulation Function
- SOP-8 Package

APPLICATIONS

- LED Bulb
- LED String



600V / 0.8A

Non-isolated Buck APFC Offline LED Driver

PIN ASSIGNMENT

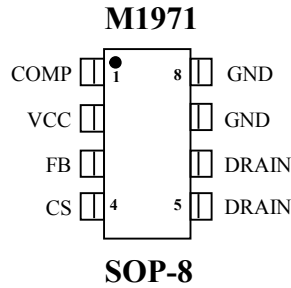

PIN DEFINITION

Pin No.	Pin name	I/O	Description
1	COMP	I	Loop Compensation Node. This pin connects a capacitor to GND for stabilization of the control loop, achieving accurate LED current , high Power Factor and low THD
2	VCC	O	Power Supply Pin. Connect a bypass capacitor from this pin to GND
3	FB		Feedback Voltage Input Pin. This pin detects the inductor demagnetization signal and the output voltage.
4	CS	I	Current Sense Pin. Connect a resistor to GND to sense the inductor current.
5,6	DRAIN		Internal HV Power MOSFET Drain.
7,8	GND	O	Ground.

FUNCTION DIAGRAM

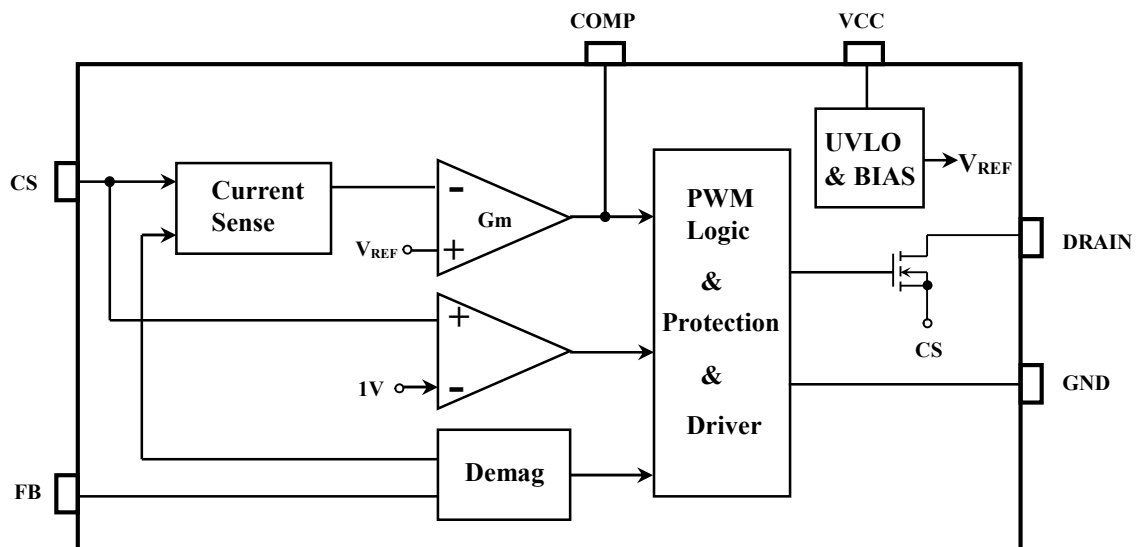



ABSOLUTE MAXIMUM RATINGS

(TA=25°C)

Parameters	Symbol	Range	Units
Internal HV MOSFET Drain to Source voltage	V _{DS}	-0.3 ~ 600	V
VCC pin maximum sink current	I _{CC_MAX}	10	mA
Compensation pin voltage	COMP	-0.3 ~ 6	V
Feedback pin input voltage	FB	-0.3 ~ 6	V
Current sense pin input voltage	CS	-0.3 ~ 6	V
Power dissipation	P _{DMAX}	0.45	W
Operating junction temperature	T _J	-40 to 150	°C
Storage temperature range	T _{STG}	-55 to 150	°C

ELECTRICAL CHARACTERISTICS

(Unless otherwise specified, V_{CC}=17V, TA=25 °C)

Parameter	Symbol	Min	Typ	Max	Units	Conditions
Supply Voltage Section						
V _{CC} Turn On Threshold	V _{CC_ON}		16.5		V	V _{CC} Rising
V _{CC} Turn Off Threshold	V _{CC_UVLO}		7.6		V	V _{CC} Falling
V _{CC} Clamp Voltage	V _{CC_CLAM}		19.5		V	
V _{CC} Startup Current	I _{CC_UVLO}		30	50	μA	V _{CC} Rising, V _{CC} = V _{CC_ON} - 1V
V _{CC} Operating Current	I _{CC}		400	500	μA	F _{OP} = 10KHz
Feedback Section						
FB Falling Edge Threshold Voltage	V _{FB_FALL}		0.2		V	FB Falling
FB Hysteresis Voltage	V _{FB_HYS}		0.15		V	FB Rising
FB Over Voltage Protection Threshold	V _{FB_OVP}		1.6		V	
Maximum On Time	T _{ON_MAX}		20		μS	
Minimum Off Time	T _{OFF_MIN}		3		μS	
Maximum Off Time	T _{OFF_MAX}		100		μS	
Current Sense Section						
CS Peak Voltage Limitation	V _{CS_LIMIT}		1.0		V	
Leading Edge Blanking Time for Current Sense	T _{LEB_CS}		350		ns	
Switch off Delay Time	T _{DELAY}		200		ns	
Compensation Section						
Internal Reference Voltage	V _{REF}	0.194	0.2	0.206	V	
COMP Low Clamp Voltage	V _{COMP_LO}		1.5		V	
COMP Linear Operating Voltage Range	V _{COMP}	1.5		3.9	V	
COMP High Clamp Voltage	V _{COMP_HI}		4.0		V	
Power MOSFET						
Static Drain-source On-resistance	R _{DS(ON)}		11.5		Ω	V _{GS} = 10V, I _D = 0.4A
Drain-Source Breakdown Voltage	B _{VDSS}	600			V	V _{GS} = 0V, I _D = 250μA
Drain-Source Diode Forward Continuous Current	I _S			0.8	μA	V _{GS} = 0V
Power MOSFET Drain Leakage Current	I _{DSS}			1.0	μA	V _{DS} = 600V, V _{GS} = 0V
Thermal Regulation Section						
Thermal Regulation Temperature	T _{REG}		150		°C	



FUNCTION DESCRIPTION

The M1971 is a high precision Active PFC driver integrating 600V power MOSFET, specially designed for non-isolated buck offline constant current LED lighting. Operating in critical conduction mode, the driver achieves high power factor, low THD and high efficiency

1. Start Up

After system powered up, the VCC pin capacitor is charged up by the startup resistor. When the VCC pin voltage reaches the turn on threshold, the internal circuits start working. The COMP pin voltage is pulled up to 1.5V quickly, and then the M1971 starts switching. The system works at 10 KHz frequency at the beginning, the COMP voltage rises up gradually, and the inductor peak current also rises up. The LED current hence achieves a soft start without overshoot. After the output voltage is built up, the VCC power is supplied by the output voltage through a diode.

2. Constant Current Controls

The M1971 utilizes patent pending floating ground structure. The inductor current is sensed during the whole switching cycle, thus it achieves high precision output current control and also excellent line and load regulation. The current in LED can be calculated by the equation :

$$I_{out} = \frac{V_{ref}}{R_{cs}}$$

V_{REF} : Internal reference voltage, typically 0.2V

R_{CS} : The current sensing resistor value

3. Feedback Network

The M1971 senses the output current zero crossing information through the feedback network, the FB falling threshold voltage is set to 0.2V with 0.15V hysteresis. The FB pin is also used to detect output OVP, the threshold voltage is 1.6V. The ratio of FB upper resistor to lower resistor can be set as :

$$\frac{R_{fbl}}{R_{fbl} + R_{fbh}} = \frac{1.6V}{V_{ovp}}$$

R_{FBL} : The lower resistor of the feedback network

R_{FBH} : The upper resistor of the feedback network

V_{OVP} : Output over voltage setting point It is recommended that the FB lower resistor set to 5KΩ--10KΩ.

4. Thermal Regulations

The M1971 integrates thermal regulation function. When the system is over temperature, the output current is gradually reduced; the output power and thermal dissipation are also reduced. The system temperature is regulated and the system reliability is improved. The thermal regulation temperature is set to 150°C internally.



600V / 0.8A

Non-isolated Buck APFC Offline LED Driver

5. Protection Functions

The M1971 offers rich protection functions to improve the system reliability. When the LED is open circuit, the output voltage will gradually rise up. The output voltage is sensed by the FB pin when power MOSFET is turned off. When FB voltage reaches the OVP threshold, it will trigger fault logic and the system stops switching. When the LED is shorted circuit, the system will work under 10 KHz switching frequency. Meanwhile, the output voltage is low and the VCC pin cannot be charged up by the output voltage, so the VCC pin voltage will gradually decrease and finally reaches the UVLO threshold. After the system enters into fault condition, the VCC voltage will decrease until it reaches UVLO threshold. Then the system will re-start again. If the fault condition is removed, the system will resume normal operation. When the output is short circuit or the inductor is saturated, the CS peak voltage will be relatively high. When CS voltage reaches the internal limitation (1V), the power MOSFET will be turned off instantaneously. This cycle by cycle current limitation can help protecting the power MOSFET, the inductor and the output diode.

TYPICAL APPLICATION

9W LED Bulb

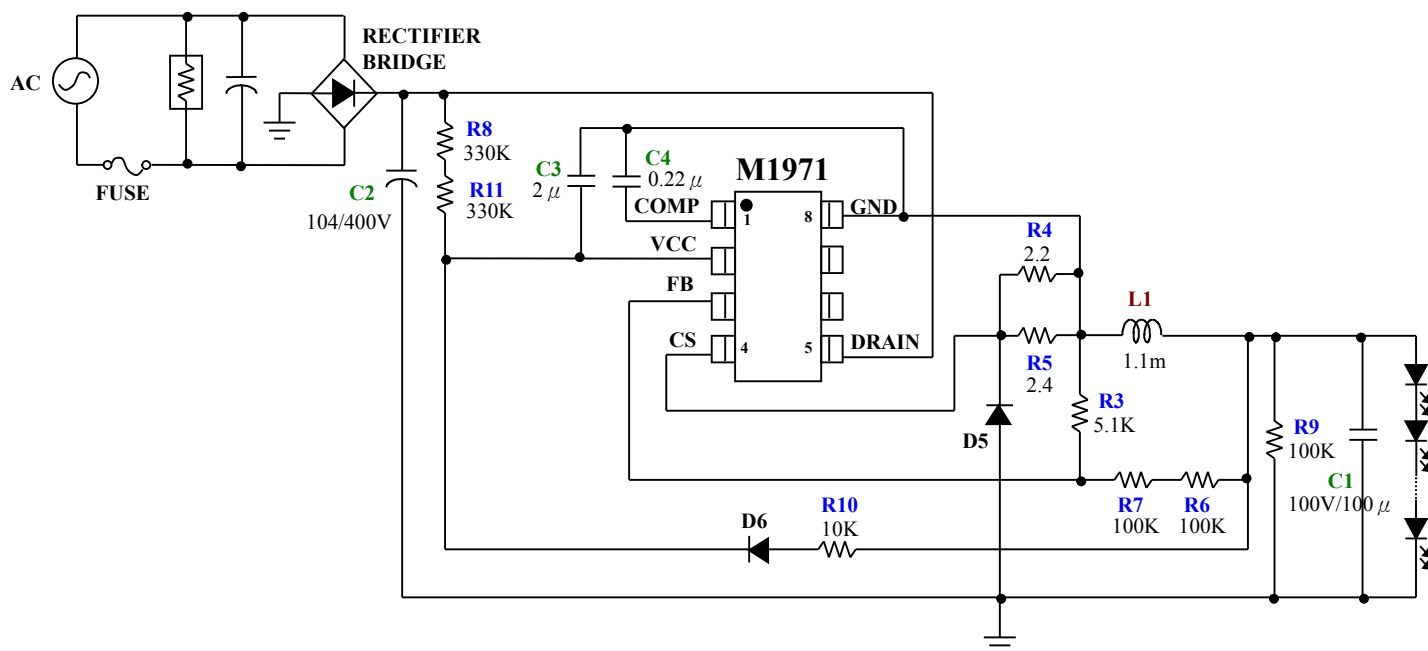



PACKAGE OUTLINE

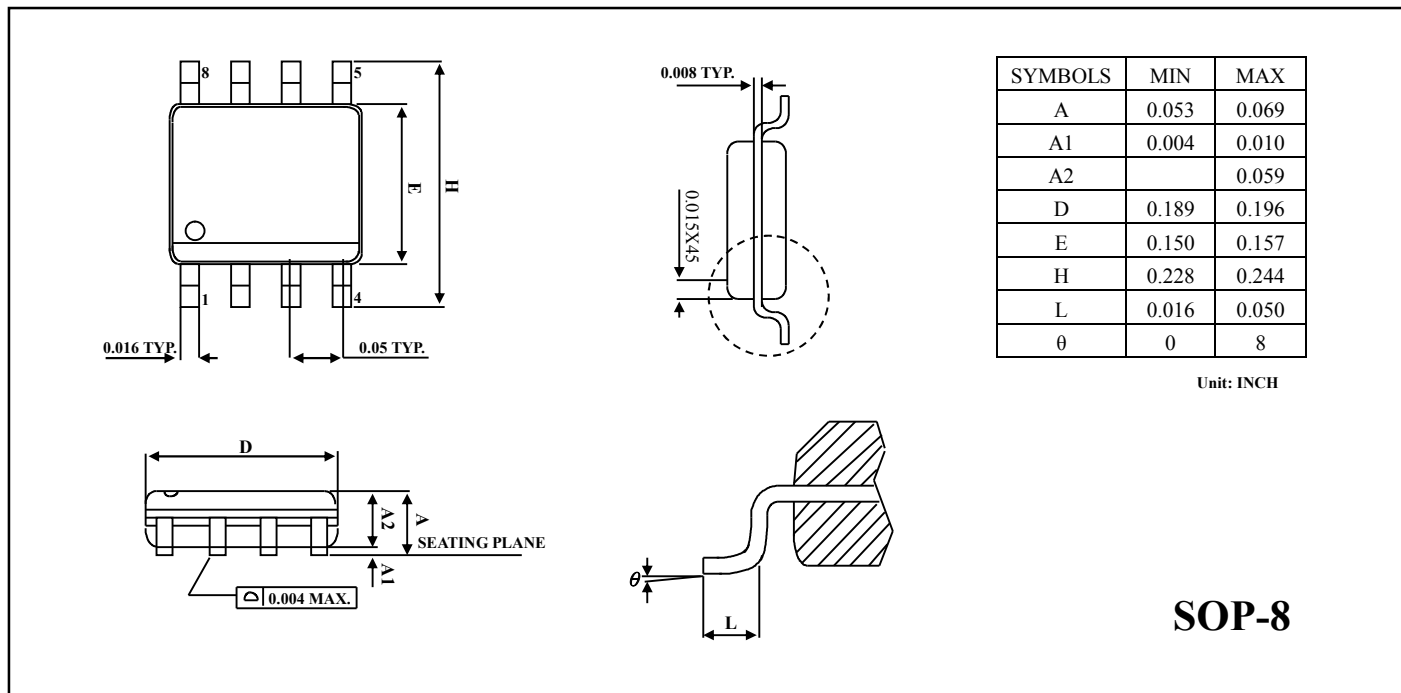

* All specs and applications shown above subject to change without prior notice.
(以上電路及規格僅供參考,本公司得逕行修正)