



3-CHANNEL RGB LED LAMP DRIVER

GENERAL DESCRIPTION

The M1355 is a 3-channel PWM enabled current sink driver for RGB LED or display applications. M1355 includes a serial buffer and data latches which convert serial input data into parallel output format, and built-in oscillator for PWM functioning. Data and clock buffer outputs are designed for cascading another chip. It is easy to be designed in applications that need mixing RGB light sources for multi-color output. The output current is determined by an external resistor and the brightness control code, both set by users.

FEATURES

- CMOS technology.
- 3 output channels for RGB LED lamps.
- Output current invariant to load voltage change.
- 8-bits luminance data with PWM current output.
- Built-in buffers for cascading clock, CK, SDA,STB to other devices.

APPLICATIONS

- LED Decorative Lighting.
- PWM Signal Generator.
- Keypad backlighting

BLOCK DIAGRAM

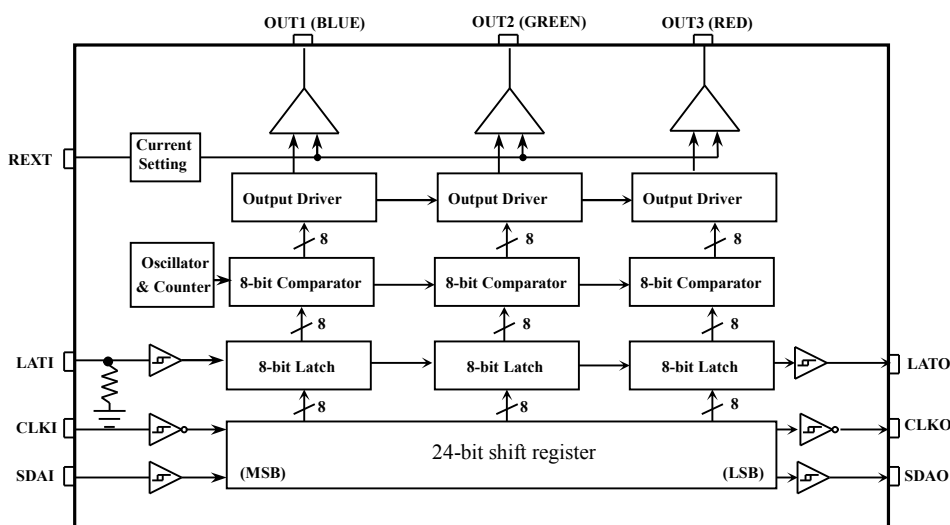



3-CHANNEL RGB LED LAMP DRIVER

PIN ASSIGNMENT

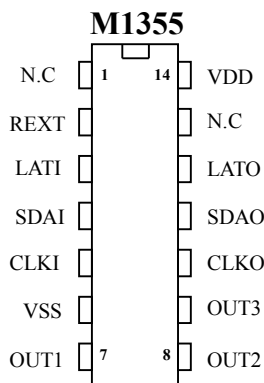

PIN DESCRIPTION

NO.	Pin Name	Type	Description
1, 13	NC		No Connection
2	REXT	INPUT	External Resistor For Setting Up Output Current For All Output Channels
3	LATI	INPUT	Latch Signal Input For 8-Bit Latches
4	SDAI	INPUT	Serial Data Input
5	CLKI	INPUT	System Clock Input
6	VSS	GND	Negative power supply
7~9	OUT1~3	OUTPUT	NMOS Output Driver(open-drain)
10	CLKO	OUTPUT	System Clock Output
11	SDAO	OUTPUT	Serial Data Output
12	LATO	OUTPUT	Latch Signal Output For 8-Bit Latches
14	VDD	POWER	Positive power supply



3-CHANNEL RGB LED LAMP DRIVER

ABSOLUTE MAXIMUM RATINGS

Characteristics	Symbol	Rating	Unit
Supply Voltage	V _{DD}	3.5 ~ 6	V
Logic Input Voltage	V _{IN}	-0.3 ~ +0.3	V
Clock Frequency	F _{CLK}	660	KHz
Output Sustaining Voltage	V _{DS}	6	V
Output Continuous Current, Each Channel	I _{OUT}	20	mA
Power Dissipation, Each Channel	P _{DISP}	100	mW
Operating Temperature	T _{OPR}	-20 ~ +85	°C
Storage Temperature	T _{STR}	-60 ~ +150	°C

ELECTRICAL CHARACTERISTICS

(V_{DD}=5V, T_a=25°C, Unless Otherwise Specified)

Characteristics	Symbol	Condition	Min.	Typ.	Max.	Unit	
Supply Voltage	V _{DD}	—	3.3	5.0	5.5	V	
Output Voltage	V _{DS}	OUT1, OUT2, OUT3 terminals	—	—	5.5	V	
Output Current	I _{OUT}	DC Test Circuit	5	—	40	mA	
Input Voltage	“H” level	V _{IH}	T _a = -20~85°C	0.7 V _{DD}	—	V _{DD}	V
	“L” level	V _{IL}	T _a = -20~85°C	0	—	0.3 V _{DD}	V
Output Leakage Current	I _{OH}	V _{OH} = 5.0V	—	0	—	μA	
OUT1	I _{OUT 1}	V _{DS} = 1.0V, R _{ext} = 6.2KΩ GBLUE = (1,1,1,1,1,1,1,1)	—	20	—	mA	
OUT2	I _{OUT 2}	V _{DS} = 1.0V, R _{ext} = 6.2KΩ GGREEN = (1,1,1,1,1,1,1,1)	—	20	—	mA	
OUT3	I _{OUT 3}	V _{DS} = 1.0V, R _{ext} = 6.2KΩ GRED = (1,1,1,1,1,1,1,1)	—	20	—	mA	
Current Skew	ΔI _{OUT}	I _{OUT} = 20mA V _{DS} = 1.0V	R _{ext} = 6.2KΩ	—	±10	—	%
Output Current Variation vs. Supply Voltage Variation	—	V _{DD} within 2.7V and 3.3V, R _{ext} = 6.2KΩ		—	±20	—	%
		V _{DD} within 4.5V and 5.5V, R _{ext} = 6.2KΩ		—	±10	—	
Pull-down Resistor	R _{IN}	LATI	—	250	—	KΩ	
Supply Current	“OUT Off”	I _{DD} (Off) 1	R _{ext} = 6.2KΩ, OUT1~OUT3 = Off, V _{DD} = 3.3V	—	1	2	mA
	“OUT On”	I _{DD} (Off) 1	R _{ext} = 6.2KΩ, OUT1~OUT3 = On, V _{DD} = 3.3V	—	1	2	
	“OUT Off”	I _{DD} (Off) 1	R _{ext} = 6.2KΩ, OUT1~OUT3 = Off, V _{DD} = 5V	—	2	3	
	“OUT On”	I _{DD} (Off) 1	R _{ext} = 6.2KΩ, OUT1~OUT3 = On, V _{DD} = 5V	—	2	3	



3-CHANNEL RGB LED LAMP DRIVER

LED Current VS Vds (@Rext = 6.2KΩ)

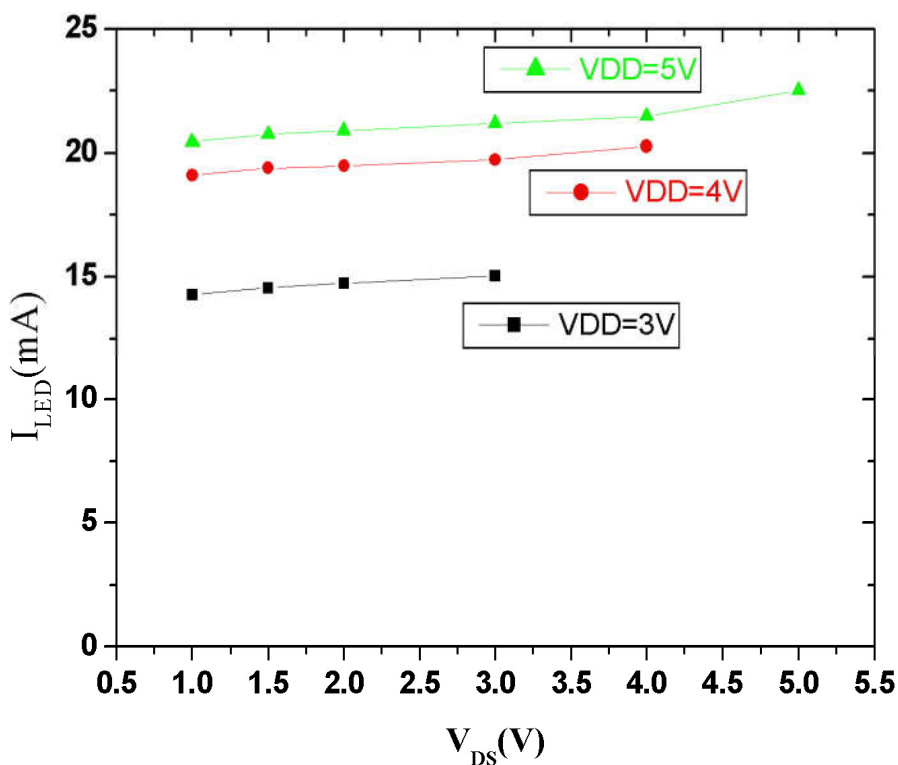

LED Current VS Resistance (@VDD=5V)

Rext (Ω)	I _{LED} (A)
2.2K	44.8m
2.7K	39.2m
3K	35.8m
3.3K	31.8m
3.6K	32m
4.7K	25.5m
6.2K	20.5m
6.8K	18.1m
8.2K	15.7m
10K	13.8m
15K	8.4m
20K	7.2m
30K	4.8m
33K	4.4m

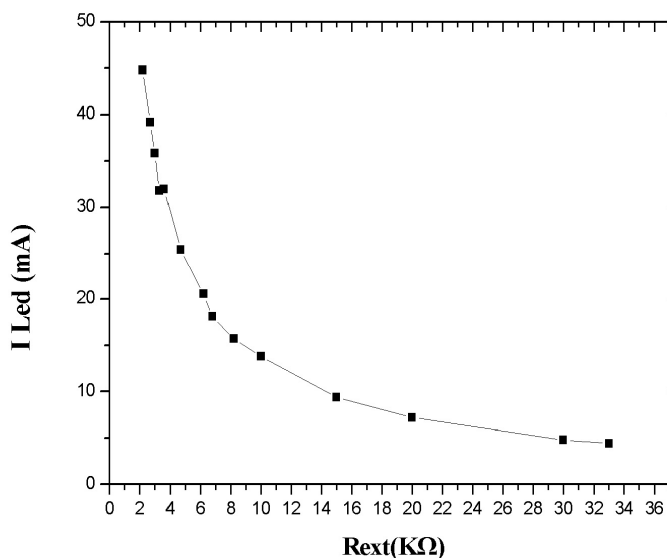



3-CHANNEL RGB LED LAMP DRIVER

TIMING CHART & CONDITION

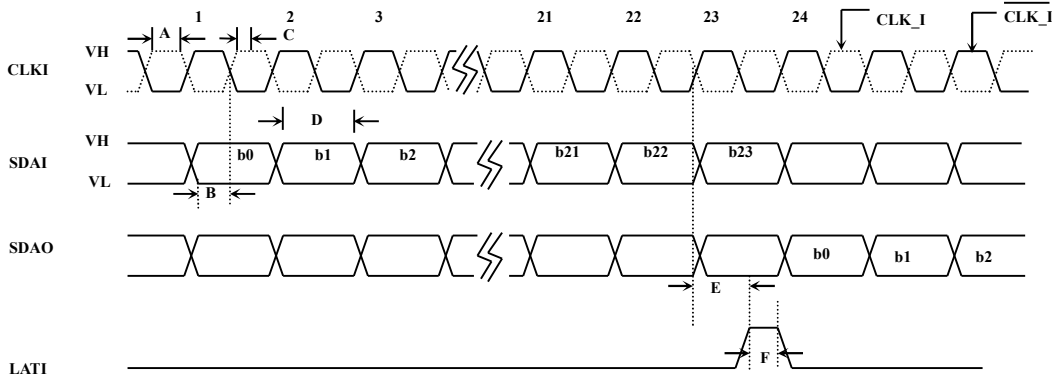

(VDD=+5V, Ta=25°C, unless otherwise specified)

Item	Description	Min	Typ	Max	Unit
A	Clock Pulse Width	50	—	—	ns
B	Serial Data Setup Time	10	—	—	ns
C	Serial Data Hold Time	10	—	—	ns
D	Serial Data Pulse Width	50	—	—	ns
E	Time Between Clock Activation And Latch	50	—	—	ns
F	Latch Pulse Width	50	—	—	ns

TRUTH TABLE

Serial Data Input	Clock Input	Shift Register Contents					Serial Data Output	Latch Input	Latch Contents								
		IN	IN-1	I2	I1			I0	IN	IN-1	I2	I1	I0		
H	↓↑	↓	H	R _N	R _{N-1}	R3	R2	R1								
L	↓↑	↓	L	R _N	R _{N-1}	R3	R2	R1								
⌋ X			R _N	R _{N-1}	R2	R1	R0									
⌋		X	X	X	X	X					R _N	R _{N-1}	R2	R1	R0
⌋		P _N	P _{N-1}	P2	P1	P0					P _N	P _{N-1}	P2	P1	P0

Internal Oscillator Output	Counter Contents					Latch Contents					NMOS Output						
	I9	I8	I7	I2	I1	I0	I9	I8	I7		I2	I1	I0		
X	L	L	L	L	L	L										
⌋	[Q9:Q0]+1 Count Up					P9					P8	P7	P2	P1	P0	If P > Q Then I _{DS} ON Else I _{DS} OFF
⌋	Q9					Q8	Q7	Q2	Q1	Q0						

L=Low Logic Level H=High Logic Level X=Irrelevant
R=Previous State P=Present State Q=Counter State



3-CHANNEL RGB LED LAMP DRIVER

An Example

Setting $R_{ext} = 6.2K\Omega$, $V_{out} = 1.0V$ for OUT1 / BLUE, OUT2 / GREEN, and OUT3 / RED, then $I(R_{ext}) = 20mA$

If the 24-bit Configuration Code is {11111111, 00000000, 10000000},

$I_{OUT1, BLUE} = G_{BLUE} / 255 \times I(R_{ext}) = 255/255 \times 20mA = 20mA$;

$I_{OUT2, GREEN} = G_{GREEN} / 255 \times I(R_{ext}) = 0/255 \times 20mA = 0mA$;

$I_{OUT3, RED} = G_{RED} / 255 \times I(R_{ext}) = 128/255 \times 20mA = 10mA$;

The mixing multi-color is determined by IOUT, GREEN = 20mA, IOUT, RED = 0mA, and IOUT, BLUE = 10mA.

Assuming Luminous Intensity (mcd) of R/G/B LEDs are the same and $I(R_{ext}) = 20mA$, we may ideally let

$G_{GREEN} + G_{RED} + G_{BLUE} = C$ (Constant value) to get a stable brightness.

For instance, while $C = 10$, that is $G_{GREEN} + G_{RED} + G_{BLUE} = 10$, M1355 can easily give system designers a wide range of color and brightness control in portable electronic devices.

TYPICAL APPLICATION

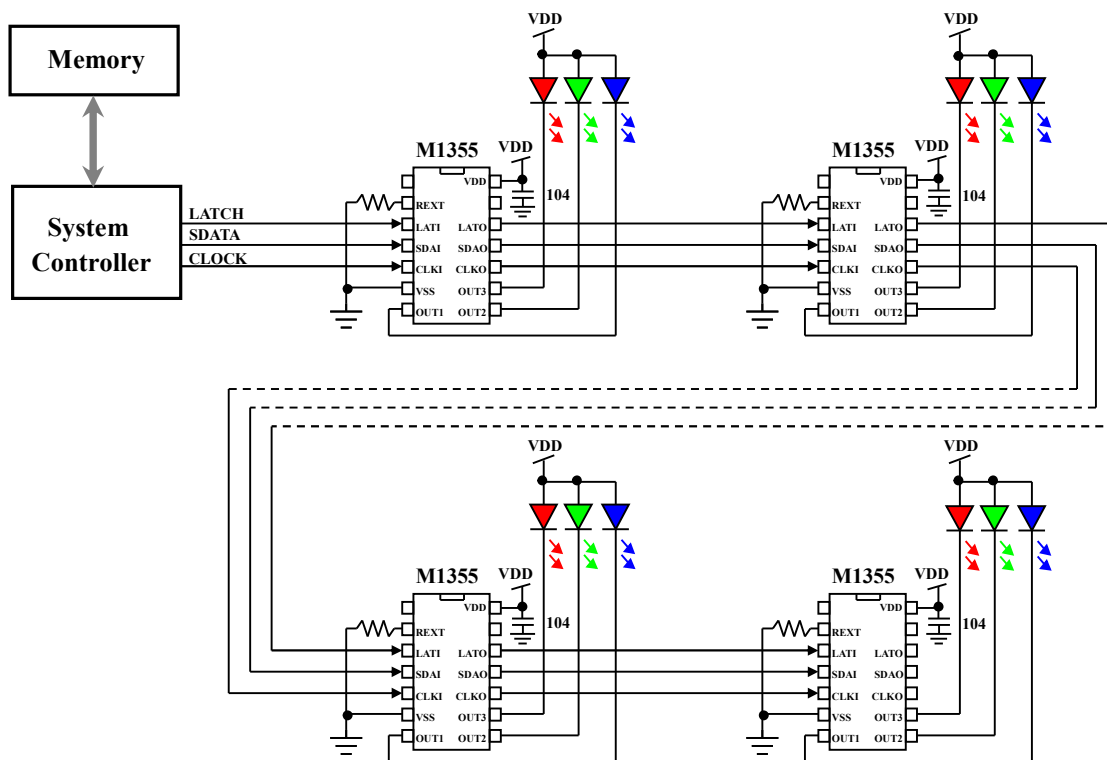

* All specs and applications shown above subject to change without prior notice.

(以上電路及規格僅供參考,本公司得逕行修正)