



DIMMER
<b>M7232</b>

## CONTINUOUS, ON/OFF LAMP DIMMER

連續, 開/關調光器

### GENERAL DESCRIPTION 功能敘述

M7232 is a CMOS integrated circuits designed for the control of brightness of incandescent lamps. The outputs control the brightness of a lamp by controlling the firing angle of a TRIAC connected with the lamp. All internal timings are synchronized with the line frequency by means of a phase-lock loop circuit and output occurs once every half-cycle of the line frequency. The brightness of the output is controlled by applying a low level at the TI input or a high level at the SL input. Function are implemented with very few interface components.

If the sensor is touched momentarily (50ms to 332ms), lamp is:

- (a) Turned off if it was on.
- (b) Turned on if it was off. The brightness resulting is either full brightness or depending on the circuit type, a previous brightness stored in the IC memory.

If the sensor is touched more than 350ms the light intensity changes slowly. As long as the touch is maintained, the change continues; the direction of change reverses whenever the maximum or minimum brightness is reached.

The IC also provides an input for slow dimming. By applying a slow clock to this input, the lamp can be dimmed slowly until total turn off occurs.

### FEATURES 產品特長

- Phase-lock loop synchronization allows use in Wall Switch applications..
- Provides brightness control of incandescent lamps with touch plates or mechanical switches.
- Control the duty cycle from 23% to 88% (conduction angles for AC half-cycle between 41° and 159°, respectively)
- Operates at 50Hz/60Hz line frequency.
- Wide range from 3.0 to 12.0 volt DC supply voltage.
- Extension input for remote activation.
- Input for slow dimming.
- 8 pin DIP package

### APPLICATIONS 產品應用

- Light dimmer, AC motor speed controller.

### PIN ASSIGNMENT

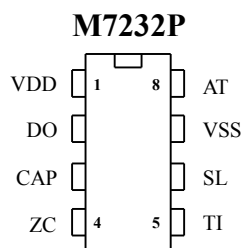



**CONTINUOUS, ON/OFF LAMP DIMMER**

連續, 開/關調光器

DIMMER
<b>M7232</b>

**PIN DESCRIPTION**

Pin No.	Pin Name	Description
1	VDD	Positive power supply
2	DO	A clock applied to this input causes the brightness to decrease in equal increments with each negative transition of the clock. Eventually, when the lamp turns off, this input has no further effect. The lamp can be turned on again by activating either the TI input or the SL input. For the transition from maximum brightness to off, a total of 83 clock pulses are needed at the DO input. When either the SENSOR or the SL input is active, the DO input is disabled.
3	CAP	The input is for the PLL filter capacitor.
4	ZC	The AC Line Frequency is applied to this input through an external RC circuit. The Phase-Lock Loop in the IC synchronizes all internal timings to the AC signal at the ZC input.
5	TI	A low level activates this input which controls the turn-on, turn-off and conduction angle $\theta$ of the TI signal with respect to the ZC input. see <b>SENSOR DURATION TABLE</b> .
6	SL	The input is functionally identical to the TI input except that a high level activates this input. It is recommended that the SL input be used instead of the TI input when long extension wires are used between Sensing plates/switches and dimmer chip.
7	VSS	Negative power supply
8	AT	The output is a low level pulse occurring once every half-cycle of the ZC input. The conduction angle $\theta$ of the output in relation to the ZC signal controls the lamp bright- ness.

The functional differences of different versions of the light dimmer ICs are explained in below Table

<b>SENSOR / TOUCH DURATION TABLE</b>				Dimming Direction Reversal
Momentary (32ms to 332ms) * Note 1		Prolonged (more than 332ms) * Note1		
Pre-Touch $\theta$	Post-Touch $\theta$	Pre-Touch $\theta$	Post-Touch $\theta$	
Off	Memory * Note 2	Off	Starts varying at Memory * Note 3	Yes
Max.	Off	Max.	Starts varying at Max	N/A
Intermediate	Off	Intermediate	Starts varying at Pre-Touch brightness	Yes

Note1 : The timings are based on  $F_s = 60\text{Hz}$ , unless otherwise specified. 50Hz timings are 1.2 times 60Hz timings.

Note2 : "Memory" refers to the conduction angle,  $\theta$  which existed prior to the current off-state. First time after power-up, the Memory value defaults to maximum conduction angle.

Note3 : First time after power-up, Long touch causes intensity to vary starting at minimum conduction angle.



DIMMER
<b>M7232</b>

**CONTINUOUS, ON/OFF LAMP DIMMER**

連續, 開/關調光器

**TIMING CHARACTERISTICS**

SYMBOL	PARAMETER	Min.	Typ.	Max.	Unit
Fs	AC Frequency	40	60	70	Hz
Ts1	Sensor duration(On/Off)	50	—	332	ms
Ts2	Sensor duration(Dimming)	350	—	Infinite	ms
Df	Doze frequency	—	—	500	Hz
TW	Output pulse width	—	33	—	us
Phase	Output phase $\emptyset$	41	—	159	degrees
—	Max. to Max. dimming time	—	7.64	—	Sec
—	A1B1=B2A2 duration	—	934	—	ms
—	B1B2 Min. intensity dwell	—	500	—	ms

\*All timings are based on Fs = 60Hz, unless otherwise specified. 50Hz timings are 1.2 times 60Hz timings.

**Output phase angle**

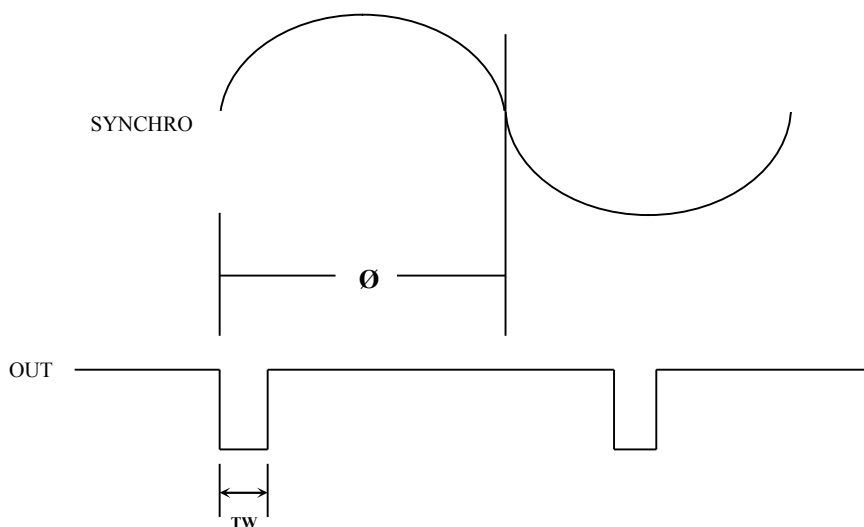

**Output phase-angle (  $\emptyset$  ) VS Sensor Input**

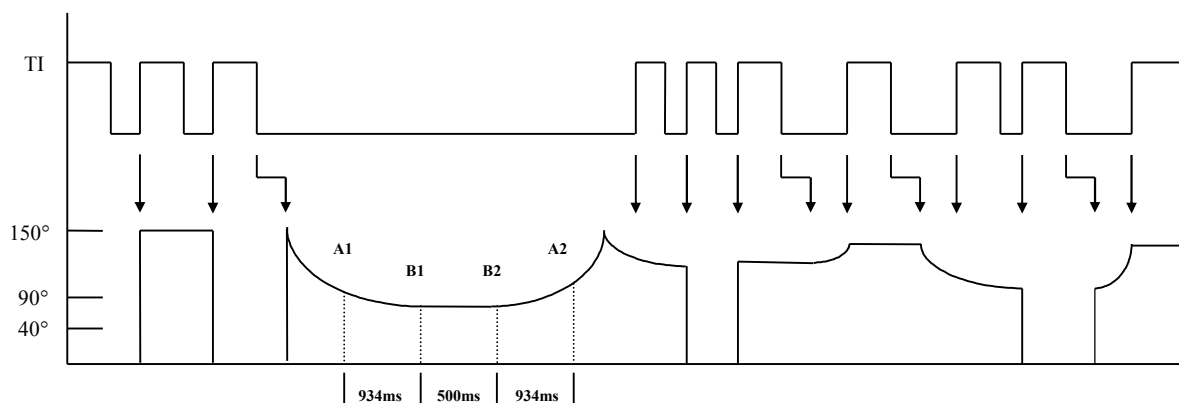

Note : Timing are indicated after initial Power-up.



DIMMER
<b>M7232</b>

**CONTINUOUS, ON/OFF LAMP DIMMER**

連續, 開/關調光器

**BLOCK DIAGRAM**

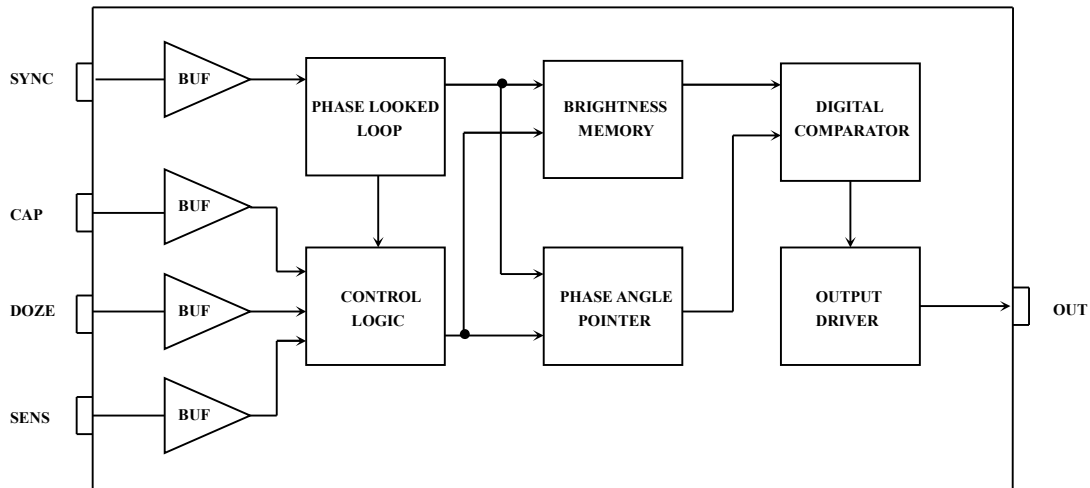

**ABSOLUTE MAXIMUM RATING**

(TA=25°C)

Parameter	Sym.	Rating	Unit
Power Supply V <sub>DD</sub> With Respect to V <sub>SS</sub>	V <sub>DD</sub> - V <sub>SS</sub>	+15	V
Voltage On Any Pin		V <sub>DD</sub> -15t o V <sub>DD</sub> +0.5	V
Operating Temperature	Top	-20 to 70	°C
Storage Temperature		-65 to 150	°C

**ELECTRICAL CHARACTERISTICS 電氣規格**

Characteristics	Sym.	Min.	Typ.	Max.	Unit	Conditions
Supply Voltage	V <sub>DD</sub>	3	5	12	V	
Stand by Current	I <sub>ST</sub>	—	400	600	uA	V <sub>DD</sub> =5volt,output off
High level input voltage	V <sub>IH</sub>	2	3	8	Volt	
Low level input voltage	V <sub>IL</sub>	1	2	5	Volt	
Output Sink Current	I <sub>SINK</sub>	—	10	—	mA	V <sub>DD</sub> =5volt, V <sub>OL</sub> = V <sub>DD</sub> -4
Output High voltage	V <sub>OH</sub>	—	5	—	Volt	
Output Low voltage	V <sub>OL</sub>	—	1.5	—	Volt	



CONTINUOUS, ON/OFF LAMP DIMMER

連續, 開/關調光器

APPLICATION EXAMPLE

A typical implementation of a lamp dimmer circuit is shown in page 5 & 6 . Here the brightness of the lamp is set by touching the SENSOR Plate. The functions of different components are as follows :

- The 5V DC supply for the chip is provided by Z, D1, R1, C3 (Page5) and C6 (Page6).
- R2 and C2 generate the filtered signal for the ZC input for synchronizing the internal PLL with the line frequency.
- R3 and C4 act as a filter circuit for the electronic extension. If extensions are not used , the SL input (Pin 6) should be tied to VSS (Pin 7).
- C8, C9, R3 set up the sensitivity of the TI input. C4 provides noise filtering .
- C1 is the filter capacitor for the internal PLL.
- R4 provides current limiting and isolation between the chip output and the TRAIC gate.
- C6 and L are RF filter circuits.

In the case of momentary power failure, the circuit state remains unchanged for a period of up to 1 sec.

For longer power interruptions, the output is shut off.

APPLICATION DIAGRAM 參考電路圖

A. TYPICAL LAMP DIMMER ( NEUTRAL NOT AVAILABLE ) 《 二線式 》

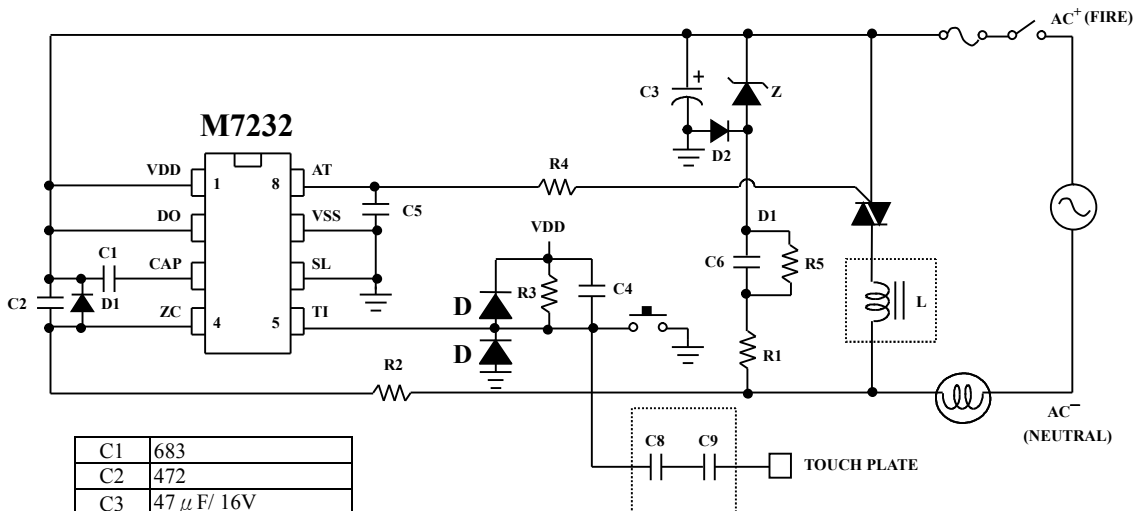

C1	683
C2	472
C3	47 $\mu$ F/ 16V
C4	681
C5	104
C6	0.22 $\mu$ F/ 400V
C8	1000PF/1000V
C9	1000PF/1000V
R1	1K $\Omega$ /2W
R2	1.5M $\Omega$
R3	1M $\Omega$
R4	100 $\Omega$
R5	1M $\Omega$
D1	1N4148
D2	1N4148
D3	1N4148
D4	1N4148
Z	5.6V/1W
L	110V/100 $\mu$ H (可省略) 220V/200 $\mu$ H



DIMMER
M7232

CONTINUOUS, ON/OFF LAMP DIMMER

連續, 開/關調光器

B. TYPICAL LAMP DIMMER ( NEUTRAL AVAILABLE ) 《 三線式 》:

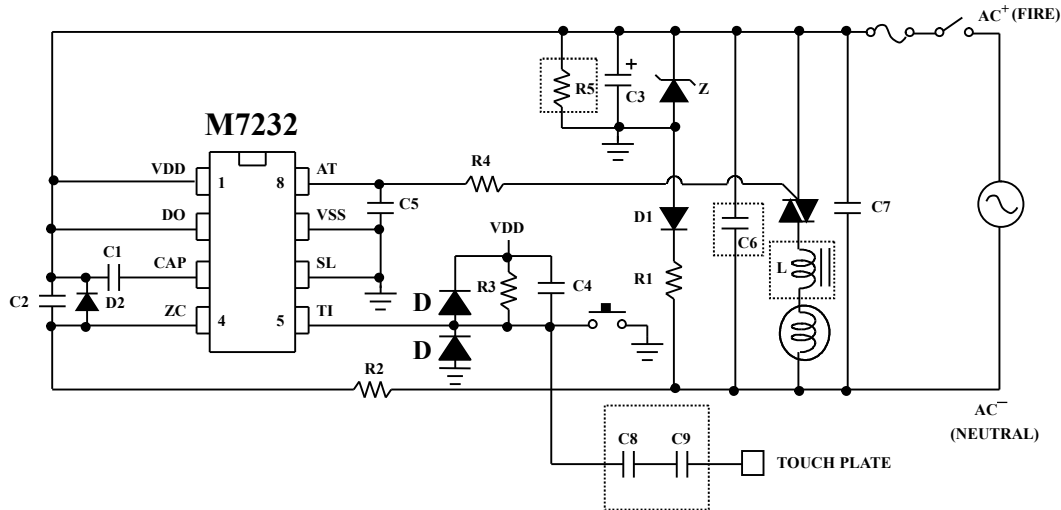

C1	0.033 $\mu$ F ~ 0.068 $\mu$ F
C2	4700PF
C3	47 $\mu$ F/25V
C4	680PF
C5	0.1 $\mu$ F
C6	0.1 $\mu$ F/ 250 ~ 400V
C7	0.1 $\mu$ F/ 250 ~ 400V
C8	1000PF/1000V
C9	1000PF/1000V
R1	39K/2W(110V) 75K/2W(220V)
R2	1.5M
R3	1M~5M
R4	100~560 $\Omega$
R5	10K
D1	4007
D2	1N4148
D3	1N4148
D4	1N4148
Z	5.6V/1W
L	110V/100 $\mu$ H 220V/200 $\mu$ H
FUSE	110V/1A 220V/1A



DIMMER
M7232

## CONTINUOUS, ON/OFF LAMP DIMMER

連續, 開/關調光器

### ELECTRONIC SWITCH EXTENSION CIRCUIT

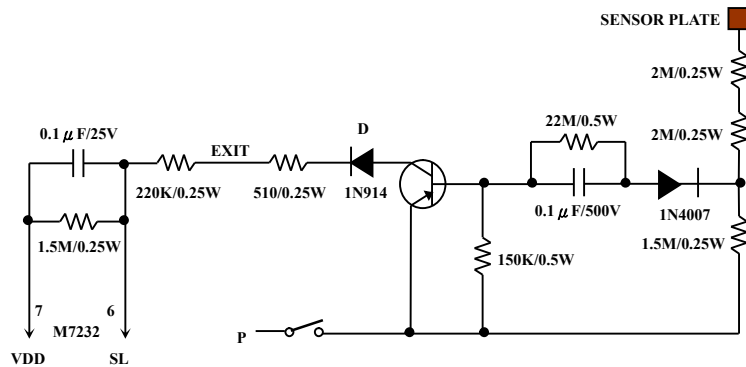

All switching and dimming functions can also be implemented by utilizing the SL input. This can be done by either a mechanical switch or the electronic switch in conjunction with a Sensing Plate. When the plate is touched, a logic high level is generated at the EXTENSION terminal for both half cycle of the line frequency.

### DOZE APPLICATION CIRCUIT

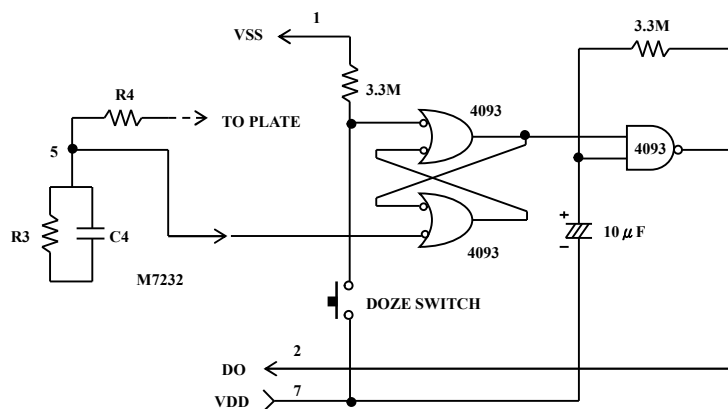

The DOZE circuit generates a slow clock (0.04Hz) at the DO terminal. If the sensor Plate is not touched, the TI terminal of the DOZE circuit sits at a logic high level. A momentary pressing of the DOZE switch sets the SR flip-flop, enabling the oscillator. Every negative transition of the clock (DO terminal) causes the light intensity to be reduced by equal increments, until eventually the light is shut off. The oscillator has no further effect on the dimmer circuit. When the light is turned on again by touching the sensor Plate, the SR flip-flop is reset and the DO clock is turned off.

\* All specs and applications shown above subject to change without prior notice.  
(以上電路及規格僅供參考,本公司得逕行修正)