



PLANE UP/DOWN
MOTORCYCLE

飞机起飞/降落声+机车声

SOUND EFFECT	
M2364B	

FEATURES 功能叙述

- Aircraft UP/DOWN. (Mode open)
- Motorcycle. (Mode = VDD)
- Independent machine gun output.
- Direct Led blinking output.

APPLICATION 产品应用

- Aircraft toys, Key chain etc.

ELECTRICAL CHARACTERISTICS 电气规格

(@V_{DD}=3V unless otherwise specified)

Characteristics	Sym.	Min.	Typ.	Max.	Unit	REMARKS
工作电压 Operating Voltage	V _{DD}	—	3	3.5	V	
工作电流 Operating Current	I _{OP}	—	0.1	0.5	mA	No load
静态电流 Quiescent Current	I _{SB}	—	1	5	μ A	
推动电流 BZ Driving Current	I _O	1	—	—	mA	@V _{DS} =1V
推动电流 LO Driving Current	I _{OL}	2	—	—	mA	@V _{DS} =1.2V
振荡频率 Oscillator Frequency	F _{OSC}	—	250	—	KHz	External±30%, Rosc=100KΩ
工作温度 Operating Temperature	Temp.	0	25	60	C°	

APPLICATION DIAGRAM 参考电路图

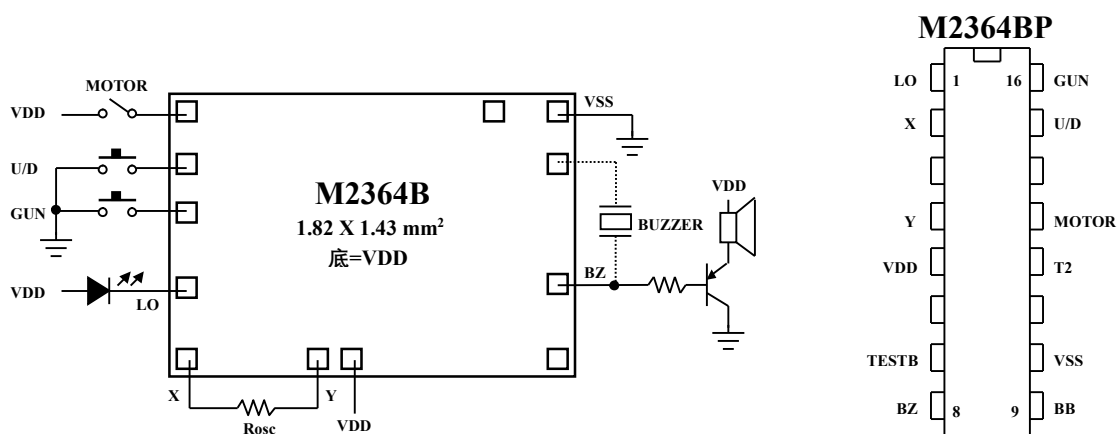

*All specs and applications shown above subject to change without prior notice.

(以上电路及规格仅供参考,本公司得径行修正)



PLANE UP/DOWN
MOTORCYCLE

飞机起飞/降落声+机车声

SOUND EFFECT	
M2364B	

PAD ASSIGNMENT & POSITION

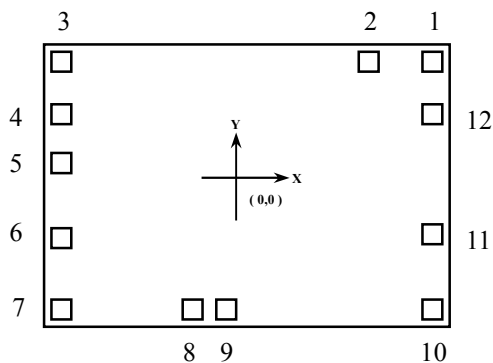

UNIT : um

No.	NAME	X	Y
1	VSS	771	523.5
2	T2	509.25	523.5
3	MOTOR	-768	522.75
4	U/D	-768	292.5
5	GUN	-768	80.25
6	LO	-768	-234.75
7	X	-768	-525
8	Y	-227.25	-525
9	VDD	-72	-525
10	TEST B	-776.25	-531
11	BZ	771	-218.25
12	BB	771	316.5

* CHIP SIZE ~ 1.82 x 1.43 mm²

* IC substrate should be connected to VDD in PCB (PCB 上 IC 必须接 VDD)